



SPECIFICATIONS

- 30qt. stainless steel bowl, fork, tool-holder shaft
- Yields 0-90 dough balls in 17-20 minute mix.
- bowl is covered in transparent polycarbonate for FC25 and 35 models. Grill is stainless steel for FC60 and 80 models.
- Chain drive system is made using trapezoidal belts and independently geared speed reducers for the bowl and fork.
- rotating parts are assembled on ball bearings.
- thick, stainless steel frame.
- electric system and safety devices meet European regulations.
- 1 year labor and parts warranty.

WEIGHT: 140 KG/ 309 LBS.
KNEAD CAPACITY: 25 KG/ 55 LBS.
FLOUR CAPACITY: 16 KG/ 35 LBS.
BOWL CAPACITY: 30 KG/ 66 LBS.
ALL MIXERS - FREIGHT CLASS 85.

Model 25 Mono/Dual

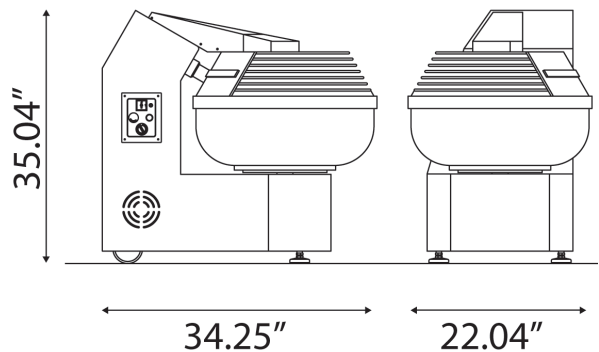

REQUIREMENTS

Motor Power= 1.5 hp
220V/1ph 15 amp for SINGLE SPEED
220V/3ph 15 amp for DUAL SPEED

Our mixers are perfect for soft doughs. The forking mixing tool “folds” rather than mixes dough, preventing friction that overheats dough and leads to a sub-par final product. Achieve perfect Neapolitan flavor by letting your oven cook your dough, NOT your mixer!