

# Enclosed Facade 130 (EF130)

## Wood-Gas Fired Ovens

*Marra Forni*



### ► Overview

Our 130 Enclosed Facade model, which is designed specifically to accommodate the high-volume pizza making of a true pizzaiolo. Maximize your kitchen space with an Enclosed Facade oven. The oven is built directly into your wall and has an optional wood storage trim kit. The 130 features a 51.18 inch deck. The dome and deck consist of refractory bricks with 4 inches of multi-layered insulation in the dome and 8 inches in the deck. The oven features a 24 inch by 9.5 inch opening along with a stainless steel flue collar. A round flue adapter comes standard on all ovens.

The oven requires a 2" tolerance in all directions, and comes standard with a fire-rated tile clay dome. The 130 Enclosed Facade model also features a 12 inch landing on the opening, as well as a control located between the deck and the top of the dome for getting a precise reading. Oven can be vented directly to the roof or vented through a powered type 1 exhaust hood with approved grease rated duct in accordance with all local and national codes. For wood burning ovens, they must be vented as a solid fuel burning appliance and must be installed following a manner that obeys all local and national codes and is acceptable to authority having jurisdiction.

### ► Approved



### ► Model Configurations

- EF130W - Wood Fired
- EF130G - Natural Gas Fired

### ► Standard Features

- Dome Terra Cotta Finish
- Turbo Burner
- Brick Deck
- Door / Fire Suppressor
- Integral Exhaust System
- Stainless Steel Flue Collar/Adapter
- Steel Stand
- Powder Coating
- 2 Year Deck and Dome Warranty
- 1 Year Parts and Labor Warranty

### ► Optional Features

- Stainless Steel Mask
- Custom Mantle
- Steel / Stainless Steel Trim Kit
- Gas Burning Accessories
- Burner Position (Left/Right)
- Exhaust Fan
- All Fuel Grease Duct
- Stainless Steel Oven Tools

\* Contact sales rep for more information about customization.

### ► Pizza Capacity

- Cooking Surface = 16.36 sq. ft.
- Pizza Capacity 8" = 10-12
- Pizza Capacity 10" = 9-11
- Pizza Capacity 12" = 8-10
- Pizza Capacity 16" = 6-7

### ► Shipping Dimensions

- Actual Weight: 4,200 LBS
- Crate Weight: 4,600 LBS
- Crate Width: 96"
- Crate Depth: 83"
- Crate Height: 84"

# Enclosed Facade130 (EF130)

Wood-Gas Fired Ovens

*Marra Forni*

Last Updated: April 22, 2016

Top View

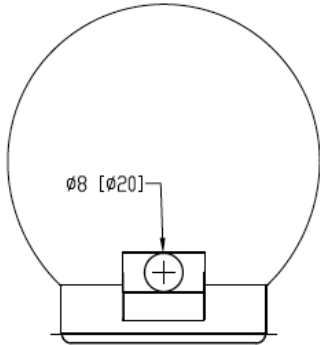

Plan View

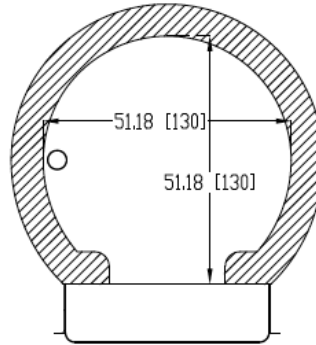

Front View

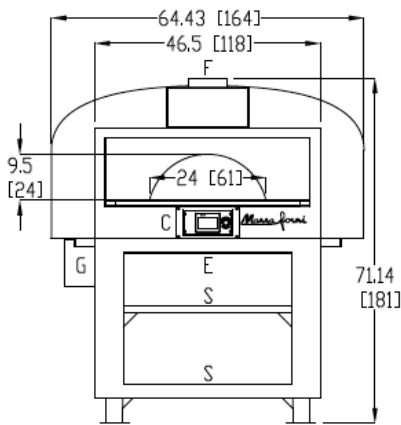

Side View

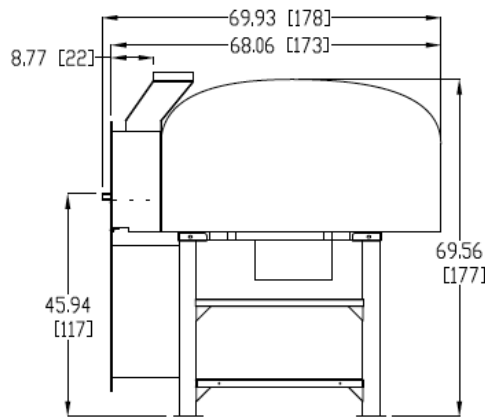

## ▶ Gas Requirements

- Gas connections 3/4" NPT per burner, quick-disconnect flex gas hose recommended.
- Pressure required 10" - 14" W.C. (Water Column) at the gas valve.
- 84,000 BTU's per burner.

## ▶ Electric Requirements

- 120V/ Single Phase / 12 Amps
- 9 ft. power cable integrated.

## ▶ Venting

- The oven is vented through an 8" round duct collar. The Neapolitan wood, gas, and combination gas-wood ovens can be installed with a listed exhaust hood system or with a chimney/grease duct vented outside without an exhaust hood, but must be installed with a power exhausted vent.
- Cubic Feet per Minute: 150CFM
- Static Pressure: 0.01"W.C

## ▶ Clearance Requirements

- 2" Minimum clearance for Combustibles on all sides.
- 0" Minimum clearance for Non Combustibles.

## Project

Job Name: \_\_\_\_\_

Model: \_\_\_\_\_

Item: \_\_\_\_\_

Fuel Type: \_\_\_\_\_

Sales Rep: \_\_\_\_\_

## Legend

**C** - Controls

**E** - Electrical Connection  
Flexible Cord

**F** - Flue Collar

**G** - Gas Connection

**S** - Storage Shelf

## Notes

\* An ongoing program of product improvement may require us to change specifications without notice.

\*All ovens are designed to suit for both commercial and residential usage.

\* Spec dimensions to be +/- 0.50 inch.

\* Oven sizes refer to dome interior size.

\*All Marra Forni ovens are ETL, NSF and VPN approved.

\*All oven Freight Class 85 and must be shipped LTL.

\* All Marra Forni ovens are approved with a door that is used as a fire suppressor. The door completely closes the front cavity of the oven. Sprinkler/ansul systems not required.