

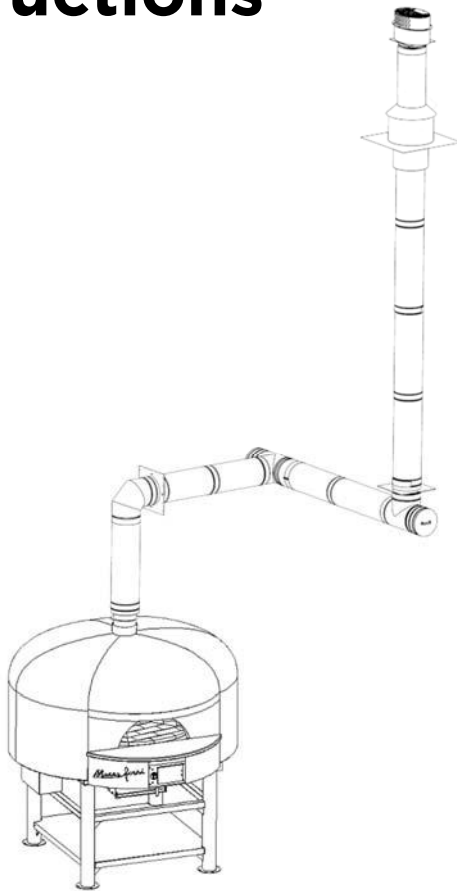

- Pizza Oven Chimney
- Grease Duct
- BBQ Chimney/Exhaust

## Model DWKL Installation Instructions



These Instructions are applicable for the following variations:

**DWKL**

**DWKL-Lt**

**A MAJOR CAUSE OF CHIMNEY RELATED FIRES IS FAILURE TO MAINTAIN REQUIRED CLEARANCES (AIR SPACES) TO COMBUSTIBLE MATERIALS. IT IS OF UTMOST IMPORTANCE THAT THIS CHIMNEY BE INSTALLED ONLY IN ACCORDANCE WITH THESE INSTRUCTIONS.**

# INDEX

## PART 1 - GENERAL INFORMATION

- 3 Introduction
- 3 DWKL Overview
- 3 Applications & Uses
- 3 Use and Installation of Individual Components
- 3 Termination Requirements
- 3 UL Listings
- 3 Slope
- 3 Features & Benefits
- 4 Part Number Identifications
- 4 Joint Assembly
- 4 KL Paste
- 4 Operating Precautions
- 5 Enclosures & Clearances
- 5 Pipe Weight
- 5 Access for Cleaning Grease Ducts

## PART 2 - SUPPORT & GUIDING

- 6 Support and Guide Spacing Options
- 6 Vertical Support Spacing & Limits
- 6 Vertical Guide Spacing
- 6 Horizontal Support Spacing
- 7 Anchor Support Plate (APS)
- 7 Heavy Duty Base (HDB)
- 8 Wall Brackets (WB)
- 8 Full Angle Ring (FAR)
- 9 Half Angle Ring (HAR)
- 9 Light Support Band (LSB)
- 9 Guy Wires Band (GWB)

## PART 3 - PIPE & OTHER LENGTHS

- 10 9" thru 48" Fixed Lengths (\_\_L)
- 10 Test/Nozzle Port Length (TPL)
- 10 Inline Access Door Length (IAD)
- 11 18" & 30" Cut Lengths (\_\_CL)
- 12 Length for Thermal Expansion
- 12 18" & 30" Adjustable Lengths w/ Graphite Packing (\_\_ALG)

## PART 4 - FITTINGS, TEE CAPS, & INCREASERS

- 13 Special Consideration for Installing Fittings
- 13 1.5° thru 90° Elbow (\_\_EL)
- 13 45°, 87°, & 90° Tee (\_\_T)
- 13 87° & 90° Degree Boot Tee (\_\_BT)
- 13 Grease Duct Tee (\_\_GT & \_\_BT)
- 14 45° Double Tee (45DT)
- 14 90° Wye Tee (90WT)
- 14 Drain Tee Caps (DCB & DCS)
- 14 Tee Cap Access (TCA)
- 14 Grease Tee Cap Access (GTAC)
- 15 Increases and Reducers
- 15 Tapered Increaser & Reducer (TI & TR)
- 15 Tapered Eccentric Increaser & Reducer (TEI & TER)
- 15 Stepped Increaser & Reducer (SI & SR)
- 15 Stepped Eccentric Increaser & Reducer (SEI & SER)

## PART 5 - ADAPTERS & TERMINATIONS

- 16 Start & End Adapters
- 16 Raw Collar Adapter (Inside) (RCIS & RCIE)
- 16 Raw Collar Adapter (Outside) (RCOS & RCOE)
- 16 Flange Collar Adapter (FCS & FCE)
- 16 Transition to Round (TRS & TRE)
- 16 Fan Plate Adapter (FPS & FPE)
- 17 Terminations
- 17 Open Termination (OTN, OTNH, OTS, & OTSH)
- 17 Exit Cone (EC & ECH)
- 18 Flat Top Rain Cap (FTN, FTNH, FTS, & FTSH)
- 18 High Wind Rain Cap (WRC)
- 18 Stack Cap (SCN, SCNH, SCS, & SCSH)

## PART 6 - THIMBLE, FLASHINGS & SHIELD

- 19 Thimble & Flashings Options
- 19 High Temperature Thimble (HTT)
- 19 Roofs with a Slope or Pitch
- 19 Flat & Pitched Roof Flashings (FRF & PRF) & Storm Collar (SC)
- 19 Unvented Rood Assembly
- 19 Flat & Pitched Cone Flashings (PCF & PCF) & Storm Collar (SCCF)

## 20 Notes

## 20 Company Information

# PART 1 - GENERAL INFORMATION

## INTRODUCTION

These instructions must be followed in all details. Failure to do so may result in a hazardous installation. Contact Marra Forni if there are any questions regarding these instructions.

The safe operation of a factory-built chimney assembly is based on the use of parts supplied by Marra Forni and the performance of the assembly may be affected if the combination of these parts is not used in actual building construction. Compliance with local code, acceptance by the local code authority (AHJ) and warranty coverage is contingent upon the DWKL system being installed and maintained in strict accordance with these installation and maintenance instructions.

Contact Local Building or Fire Officials about restrictions and installation inspection in your area.

## DWKL OVERVIEW

DWKL is the designation model number for Marra Forni's Double Wall conical Grease Duct and Chimney system. The -Lt variation has a different inner gage thickness. For the purpose of these installation instructions, both DWKL and the DWKL-Lt will be treated together. Differences in UL Listings, installation, and weights will be shown where needed.

## APPLICATIONS & USES

Model DWKL factory built exhausts are suitable for use in the removal of smoke and grease laden vapors from commercial, institutional, industrial, and similar type of applications.

See UL Listings and Clearances sections for maximum temperatures and required clearances to combustibles at different operating temperatures.

## USE AND INSTALLATION OF INDIVIDUAL COMPONENTS

These instructions comprise both general and specific requirements for all parts in the product line. Before specifying a design or beginning an installation, these instructions should be carefully reviewed.

## TERMINATION REQUIREMENTS

Per NFPA-211, building heating appliance chimneys are required to terminate a minimum of 3' above the highest point where it passes through a roof of a building and a minimum of 2' higher than any part of the building within a horizontal distance of 10'. There are exceptions to this requirement, such as mechanical draft and various listed appliances with other requirements, so consult with the Authority Having Jurisdiction for actual requirements if in question.

Strictly follow NFPA-96 for the termination requirements for Grease Duct and/or kitchen exhaust duct systems.

## UL LISTINGS

**UL-1978 Standard, Grease Duct** - under this Listing, Model DWKL (and DWKL-Lt variation) have been determined suitable for Grease Ducts as defined by NFPA-96, the "Standard for Ventilation Control and Fire Protection of Commercial Cooking Operations". UL confirmed proper minimum air space clearance to combustibles for 500°F continuous exhaust gas temperatures and 2000°F exhaust gas temperature for 30 minutes simulating a kitchen exhaust fire. UL also confirmed that the installed joints are grease and smoke tight.

**UL-103 Standard, Building Heating Appliance Chimney Listing** - under this Listing, Model DWKL (and DWKL-Lt variation) have been determined suitable for venting flue gases from gas, liquid and solid fuel fired appliances at a temperature not exceeding 1000°F (540°C) continuously, 1400°F (760°C) intermittent (maximum one hour), and 1700°F (930°C) brief (maximum 10 minutes) is also permitted under this application.

**UL-103 Standard, Additional Type HT Listing** - Model DWKL (and DWKL-Lt variation) have qualified for UL's additional, optional Type HT rating for Building Heating Appliance Chimneys which indicates they have been evaluated and found suitable for exposure to 2100°F flue gases for 10 minutes. Many local authority having jurisdictions require a Type HT rating for chimneys for certain appliance venting applications, especially with solid fuel.

**UL-103 Standard, Additional Positive Pressure Listing** - UL has confirmed that Model DWKL (and DWKL variation) exhaust and chimney system is suitable for use at maximum 90 inch water column internal pressure when used in positive pressure applications. This 90 inch water column was measured after the exhaust was influenced by UL-2561's continuous 1400°F flue gas temperatures.

## SLOPE

Mechanical codes and good practice require that some slope (back to a grease reservoir or kitchen hood) be created to prevent pooling of grease within horizontal portions of grease duct systems. Per code, grease duct systems are required to incorporate a minimum ¼" per foot slope. Some codes require ¼" per foot for runs less than 75' in length and 1" per foot for runs of 75' and more.

While such slopes are critically important for flat bottom grease ducts in order to prevent pooling, it is well acknowledged that cylindrical ducts prevent pooling with far less slope.

Engineering analysis, including hydraulic fluid calculations and tests confirm that pooling of grease within factory-built, cylindrical grease duct systems can be achieved with far less slope compared to flat bottomed systems, due to the physical characteristics of their construction.

As such, per the terms of the UL Listing and in accordance with UL1978, Marra Forni recommends a minimum slope of 1/16" per foot (0.3 degrees) for horizontal segments of the DWKL grease duct systems. Normal system components will permit such slopes to be achieved on horizontal offsets of at least 2' in dimension. Shorter runs require no slope. Where a specific slope is desired, Marra Forni offers various options including 1.5°, 3° and 87° elbows as well as 87° tees.

## FEATURES & BENEFITS

Model DWKL is a cylindrical, factory built, modular exhaust systems that incorporate a steel to steel conical joint and clamp system for quick and easy assembly in the field. The conical joint is tapped in place creating a gas and liquid tight seal where sealant is not needed.

The conical joints have a 2.2" wide steel to steel surface overlap area at each connection allowing greater stiffness, sealing, and durability over ½" flange to flange systems. Example, 6" I.D. DWKL have a 41.45 in<sup>2</sup> surface area at the joint where a ½" flanged systems has 9.42 in<sup>2</sup>.

# PART 1 - GENERAL INFORMATION

The double wall Model DWKL is insulated with 1¼" thick compressed fiber which allows the inner and outer pipes to stay aligned, without the use of additional clips or brackets, eliminating hot spots at the joint connections.

Figure 1-1, Model DWKL Assembly Detail

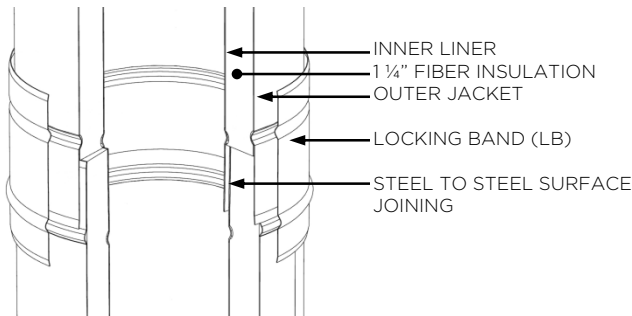

Further features of Model DWKL double wall and fiber insulated include:

- a) Easier to clean than field welded rectangular
- b) Reduced clearance to combustibles
- c) Reduced outer pipe skin temperatures
- d) Reduced building heat gain
- e) Increased efficiencies of energy recovery systems
- f) Reduced noise levels caused by high velocity exhausts

## PART NUMBER IDENTIFICATIONS

These instructions identify Model DWKL item code in text and illustrations. Actual part numbers include the Model (DWKL), diameter, item code, and variation (none or -Lt)

Example 1: DWKL8-36L for an 8 inch inner diameter Model DWKL double wall 36 inch length of pipe.

Example 2: DWKL12-87BT-Lt for a 12 inch inner diameter Model DWKL double wall 87" Boot Tee in the -Lt variation.

## JOINT ASSEMBLY

The Model DWKL joint system is designed for a quick and easy installation. Follow Steps 1 through 4 for general pipe and fittings assembly.

Figure 1-3, Model DWKL Assembly

### Step 1

Clean the inner side of the female end and the outer side of the male end of each inner liner. Apply the KL Paste to the female end.

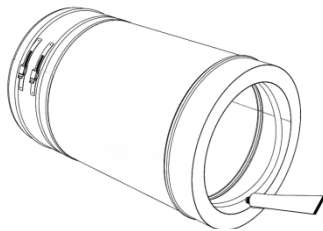

### Step 2

Use your hands to center both pipes in alignment. Connect both pipes and press them together as much as possible by hand.

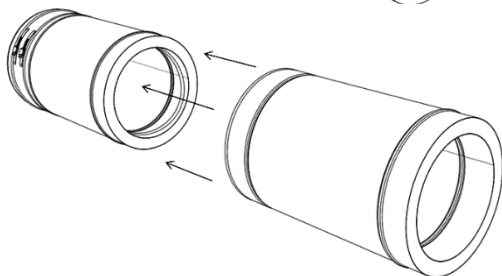

### Step 3

Use the wood plate (supplied with shipment) and place it on the end of the assembly.

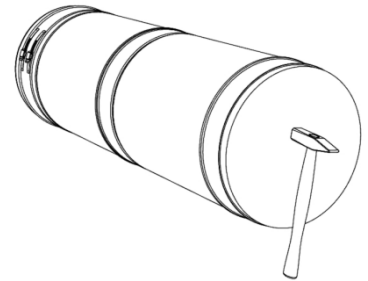

Tap 2-3 times. Make sure to press both inner and outer pipes together; the inner should not be more than 1/8" longer than the outer pipe once the male/female conical ends are engaged.

### Step 4

Install and fix the Locking Band (LB). To ensure the connection is completely in place, the Locking Band has to be perfectly fitted in both grooves.

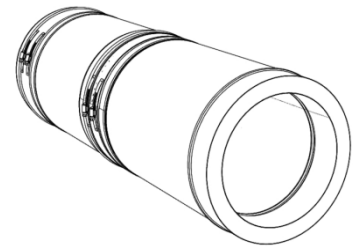

## KL PASTE

KL Paste is a ceramic lubricating and assembly paste. The purpose is to help guide the pipe connections to assure the best steel to steel connection. It also seals the joint by allowing the ceramic to fill any microscopic steel imperfections. On fittings it will help the installer rotate to the correct position before tapping in place.

Use approximately 1 teaspoon of paste per 24" length of joint perimeter. Example: 10 inch diameter has 31" of perimeter length, so use about 1.3 teaspoons per each 10 inch joint connection. Below table allows for a 20% waste.

Table 1-1, No. (#) of Joints per 3.5 oz. Tube

Ø	3"	4"	5"	6"	7"	8"	9"	10"	11"	12"	13"	
#	42.6	32.0	25.6	21.3	18.2	16.0	14.2	12.8	11.6	10.6	9.8	
	14"	16"	18"	20"	22"	24"	26"	28"	30"	32"	34"	36"
	9.1	8.0	7.1	6.4	5.8	5.3	4.9	4.5	4.2	4.0	3.7	3.5

## OPERATING PRECAUTIONS

### Creosote and Soot - Formation and Need for Removal

When wood is burned slowly, it produces tar and organic vapors which combines with expelled moisture in the flue gases to form creosote. The creosote vapors condense in the cool chimney flue of a slow burning fire. As a result, creosote residue accumulates on the inner pipe. If ignited, this creosote makes an extremely hot fire.

For this reason, the chimney should be inspected at least once every two months during the heating season to determine if a creosote or soot buildup has occurred. If creosote or soot has accumulated, it should be removed to reduce risk of a chimney fire.

# PART 1 - GENERAL INFORMATION

## ENCLOSURES & CLEARANCES

Model DWKL Building Heating Appliance Chimney and Grease Duct is intended to be installed unenclosed or with non-combustible enclosures, and is not for use in one or two story family dwellings.

If the Chimney or Grease Duct passes through any zone or story of a building outside of which the connected appliance or hood is located, it is to be enclosed in non-combustible construction having a fire rating equal to or greater than that of the wall or ceiling through which it passes. Check with the local code authority (AHJ) for material with an appropriate fire rating.

Where, according to local code, no chase enclosure is required, Model DWKL may be installed adjacent to a wall of combustible construction at the minimum airspace clearance specified on each pipe section and in the individual Listing as shown in the following tables.

Table 1-2, DWKL Airspace Clearances to Combustibles

Inside Diameter	DWKL Double Wall Grease Duct	DWKL Type HT 1000F Chimney
3" (76mm)	2.00" (50.8mm)	0.50" (12.7mm)
4" (102mm)	2.00" (50.8mm)	0.50" (12.7mm)
5" (127mm)	2.00" (50.8mm)	0.50" (12.7mm)
6" (152mm)	2.00" (50.8mm)	0.50" (12.7mm)
7" (178 mm)	2.00" (50.8mm)	0.75" (19.1mm)
8" (203mm)	2.00" (50.8mm)	0.75" (19.1mm)
9" (229mm)	2.00" (50.8mm)	0.75" (19.1mm)
10" (254mm)	2.00" (50.8mm)	0.75" (19.1mm)
11" (249mm)	2.00" (50.8mm)	0.75" (19.1mm)
12" (305mm)	2.00" (50.8mm)	0.75" (19.1mm)
13" (330mm)	2.00" (50.8mm)	0.75" (19.1mm)
14" (356mm)	2.00" (50.8mm)	0.75" (19.1mm)
16" (406mm)	3.00" (76.2mm)	1.00" (25.4mm)
18" (457mm)	3.00" (76.2mm)	1.00" (25.4mm)
20" (508mm)	3.00" (76.2mm)	1.00" (25.4mm)
22" (559mm)	3.00" (76.2mm)	1.00" (25.4mm)
24" (610mm)	3.00" (76.2mm)	1.00" (25.4mm)
26" (660mm)	3.00" (76.2mm)	1.00" (25.4mm)
28" (711mm)	3.00" (76.2mm)	1.00" (25.4mm)
30" (762mm)	3.00" (76.2mm)	1.00" (25.4mm)
32" (812mm)	4.00" (101.6mm)	1.00" (25.4mm)
34" (863mm)	4.00" (101.6mm)	1.00" (25.4mm)
36" (914mm)	4.00" (101.6mm)	1.00" (25.4mm)

For clearances to combustibles for other items such as thimbles, see PART 6 - THIMBLE & FLASHINGS in these instructions.

Do not wrap or place any type of insulation in the required clearances space surrounding the Chimney in an effort to reduce the clearance to combustibles or to create some sort of fire protective enclosure.

### Clearance to non-combustibles:

As required for installation, access, inspection, or per local code.

## PIPE WEIGHT

The approximate installed weight of the DWKL exhaust systems can be found using this table. This table does not include accessories such as supports and guides, nor shipping packaging or palletizing weight.

Table 1-3, DWKL Installed Weight in Lb/ft (kg/m)

Inside Diameter	DWKL	DWKL-Lt
3" (76mm)	3.5 (5.1)	3.0 (4.4)
4" (102mm)	4.4 (6.5)	3.8 (5.7)
5" (127mm)	5.3 (7.9)	4.4 (6.5)
6" (152mm)	6.3 (9.3)	5.4 (8.0)
7" (178 mm)	7.2 (10.7)	6.1 (9.1)
8" (203mm)	8.1 (12.1)	6.8 (10.1)
9" (229mm)	9.1 (13.5)	7.6 (11.3)
10" (254mm)	10.0 (14.9)	8.4 (12.5)
11" (249mm)	10.9 (16.3)	9.1 (13.5)
12" (305mm)	11.9 (17.7)	10.0 (14.9)
13" (330mm)	12.8 (19.1)	10.7 (15.9)
14" (356mm)	13.8 (20.5)	11.6 (17.3)
16" (406mm)	15.6 (23.2)	13 (19.3)
18" (457mm)	17.5 (26.0)	14.6 (21.7)
20" (508mm)	19.4 (28.8)	16.2 (24.1)
22" (559mm)	21.3 (31.6)	17.8 (26.5)
24" (610mm)	23.1 (34.3)	19.2 (28.6)
26" (660mm)	23.7 (35.3)	DNA
28" (711mm)	25.5 (37.9)	DNA
30" (762mm)	27.2 (40.5)	DNA
32" (812mm)	29.0 (43.2)	DNA
34" (863mm)	30.7 (45.7)	DNA
36" (914mm)	32.5 (48.4)	DNA

## ACCESS FOR CLEANING GREASE DUCTS

Follow NFPA-96 for required openings in Grease Duct for accessibility required for thorough cleaning.

Following are some openings requirements as mentioned in NFPA-96:

- 1) Openings at changes of direction, if not accessible from the duct entry or discharge.
- 2) Access panel openings for installation and servicing of fire-extinguishing systems.
- 3) Access for cleaning and inspection where fans with ductwork connected on both sides within 3' of each side of fan.

Horizontal grease ducts only:

- 4) Opening for thorough cleaning at 12' intervals, where opening is not large enough for personnel entry.

Vertical grease ducts only:

- 5) Access at the top of a vertical riser to accommodate personnel descent.
- 6) Where personnel entry is not possible, access at every floor.

Model DWKL has two standard options for access panels in Grease Duct systems. These are no-tool in design and specifically tested and Listed for Grease Duct use.

- Inline Access Door (IAD), see Section 3.
- Grease Duct Tee Cap Access (GTCA), see Section 4.

# PART 2 - SUPPORT & GUIDING

## SUPPORT AND GUIDE OPTIONS

Model DWKL is very versatile in nature so there are many options for supporting and guiding, see in great details each option later in this section:

- 1) Anchor Plate Support (APS)
- 2) Heavy Duty Base for Support/Ring (HDB)
- 3) Wall Brackets for Support/Ring (WB)
- 4) Light Support Band (LSB)
- 5) Full Angle Ring (FAR)
- 6) Half Angle Ring (HAR)
- 7) Guy Wires band (GWB)

## VERTICAL SUPPORT SPACING & LIMITS

Figure 2-1 provides the maximum vertical support spacing for various support options (Dimension A). See Table 2-1 for maximum distances.

Figure 2-1, Maximum Vertical Support Spacing

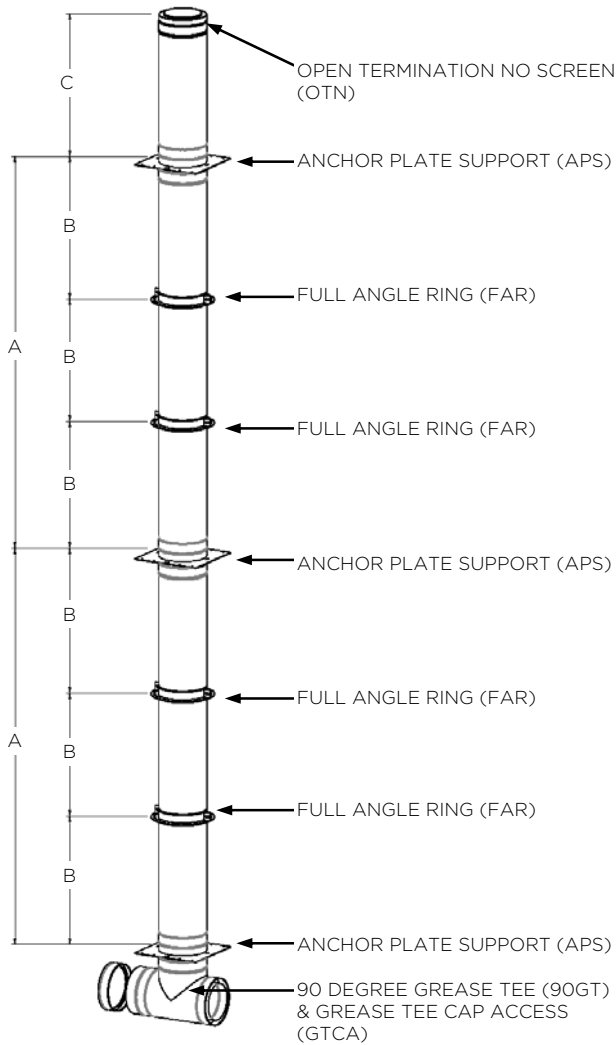

NOTE: See PART 3 "Lengths for Thermal Expansion" in these instructions for important use of expansion joints between anchor plate support locations.

Table 2-1, Vertical Support Spacing Limitations (Dim A)

Vertical Support Method / Part Nos.	Dim A - Maximum Support Height	
	Diameter	DWKL
<b>Anchor Plate Support / APS</b>		
3" - 6" (76 - 152mm)	300' (91.4m)	300' (91.4m)
7" - 10" (178 - 254mm)	208' (63.3m)	248' (75.5m)
11" - 13" (279 - 330mm)	162' (49.3m)	194' (59.1m)
14" - 18" (356 - 457mm)	119' (36.2m)	142' (43.2m)
20" - 24" (508 - 610mm)	90' (27.4m)	108' (32.9m)
26" - 30" (660 - 762mm)	88' (26.8m)	DNA
32" - 36" (813 - 914mm)	86' (26.2m)	DNA
<b>Anchor Plate Support with Heavy Duty Base / APS &amp; HDB</b>		
3" - 6" (76 - 152mm)	300' (91.4m)	300' (91.4m)
7" - 10" (178 - 254mm)	300' (91.4m)	300' (91.4m)
11" - 13" (279 - 330mm)	300' (91.4m)	300' (91.4m)
14" - 18" (356 - 457mm)	224' (68.2m)	269' (81.9m)
20" - 24" (508 - 610mm)	170' (51.8m)	205' (62.4m)
26" - 30" (660 - 762mm)	111' (33.8m)	DNA
32" - 36" (813 - 914mm)	93' (28.3m)	DNA
<b>Anchor Plate Support with Wall Bracket / APS &amp; WB</b>		
3" - 6" (76 - 152mm)	70' (21.3m)	81' (24.6m)
7" - 10" (178 - 254mm)	44' (13.4m)	52' (15.8m)
11" - 13" (279 - 330mm)	34' (10.3m)	41' (12.4m)
14" - 18" (356 - 457mm)	25' (7.6m)	30' (9.1m)
20" - 24" (508 - 610mm)	19' (5.7m)	23' (7.0m)
26" - 30" (660 - 762mm)	12' (3.7m)	DNA
32" - 36" (813 - 914mm)	10' (3.0m)	DNA

## VERTICAL GUIDE SPACING

Table 2-2 provides the maximum vertical guide spacing (Dimension B) for all guide options. Also shown is the maximum freestanding distance above the last support or guide (Dimension C).

Applicable vertical guides are FAR Full Angle Ring, LSB Light Support Band, and GWB Guy Wires Band

Table 2-2, Vertical Guide Spacing (Dim B and C)

Vertical Guide Spacing	DWKL		DWKL-Lt	
	B	C	B	C
3" (76mm) to 24" (610mm)	19.5' (5.9m)	10.0' (3.0m)	14.6' (4.4m)	7.5' (2.2m)
26" (660mm) to 36" (914mm)	20.2' (6.2m)	8.2' (2.5m)	DNA	DNA

## HORIZONTAL SUPPORT SPACING

Table 2-3 provides the maximum unsupported horizontal spacing (distance) between guides for an exhaust installed inside the building.

Applicable horizontal supports are FAR Full Angle Ring, HAR Half Angle Ring, LSB Light Support Band, and GWB Guy Wires Band.

# PART 2 - SUPPORT & GUIDING

Table 2-3, Horizontal Support Spacing

Maximum Unsupported Horizontal Spacing	DWKL	DWKL-Lt
3" (76mm) - 14" (356mm)	15.0' (4.5m)	11.3' (3.4m)
16" (406mm) - 24" (610mm)	12.0' (3.7m)	6.8' (2.1m)
26" (660mm) - 36" (914mm)	9.0' (2.7m)	DNA

## ANCHOR PLATE SUPPORT (APS)

The Anchor Support Plate consists of a short length of pipe that has a single heavy plate factory welded to the inner pipe. It is intended to provide maximum support to vertical sections and to provide an anchor support for horizontal sections.

Figure 2-2, Anchor Plate Dimensions

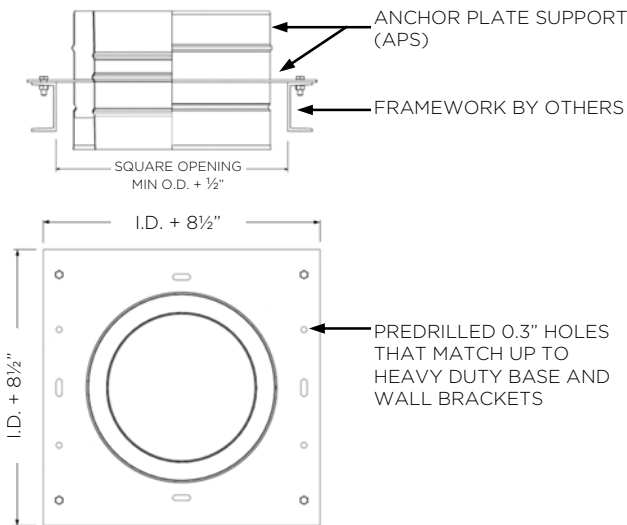

The plate must be braced back to the building structure or support with rigid structural members by the installing contractor. The structural project engineer should select support members in accordance with good engineering practice to suit each specific application, or follow the guidelines to meet the following figures.

Figure 2-3, Anchor Plate Support for Vertical

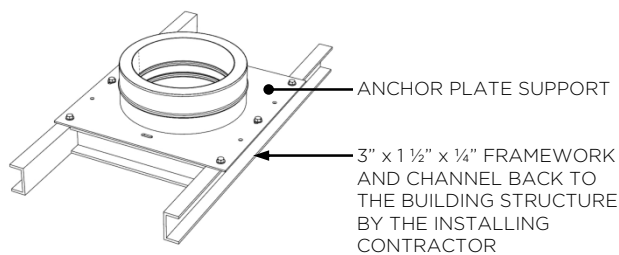
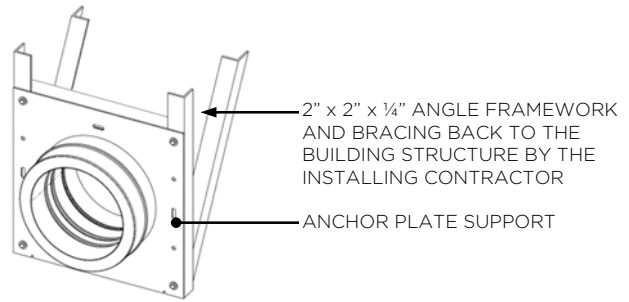

Figure 2-4, Anchor Plate Support for Horizontal



The Anchor Plate Support may only be attached to non-combustible construction such as block, concrete, or steel.

**DO NOT ATTACH THE ANCHOR SUPPORT PLATE TO COMBUSTIBLE MATERIALS.**

## HEAVY DUTY BASE (HDB)

This is a factory-built base and framework for the Anchor Plate Support allows quick and easy installations when bracing the support back to the building structure. The installing contractor only provides the channel as Heavy Duty Base acts as the framework.

Hardware for attaching the APS Anchor Plate Support to the HDB Heavy Duty Base is supplied with the base.

Figure 2-5, Heavy Duty Base Support for Vertical

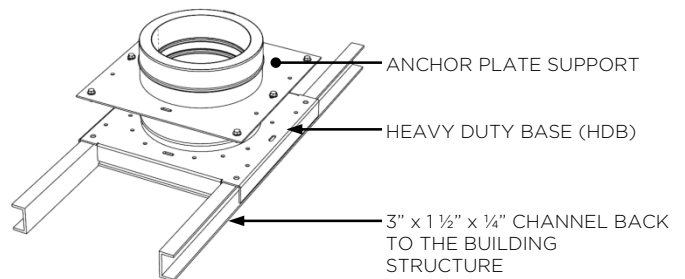
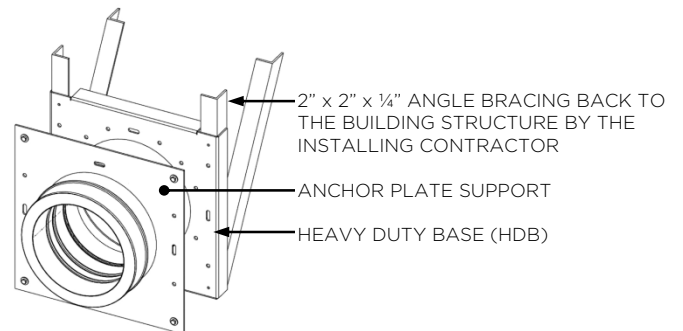

Figure 2-6, Heavy Duty Based Support for Horizontal



## PART 2 - SUPPORT & GUIDING

### WALL BRACKETS FOR SUPPORT (WB)

These Wall Brackets will conveniently support the Anchor Plate Support back to a non-combustible wall.

Figure 2-7, Wall Brackets

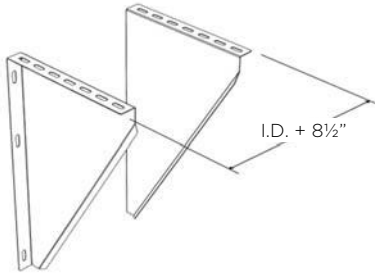

Hardware for attaching the Anchor Plate Support to the Wall Brackets is supplied with the brackets.

However, hardware for attaching these Wall Brackets to the wall is by others. The structural engineer should select hardware and in accordance with good engineering practice to suit each specific application.

Figure 2-8, Wall Brackets for Anchor Plate Support

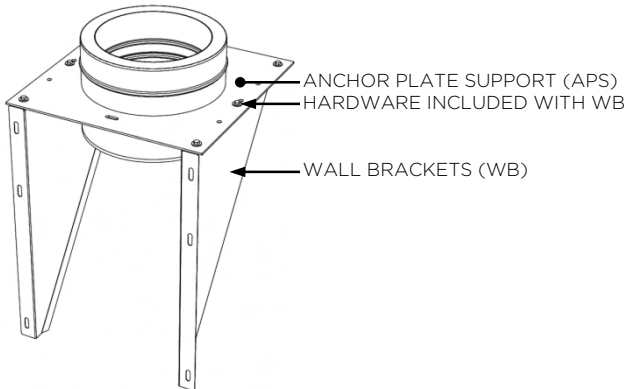

### FULL ANGLE RING (FAR)

The Full Angle Ring is used as a vertical guide and is braced to the building structure by the installing contractor. It can also be used in horizontal configurations where exposed to weather (wind) or on vibrating or high pressure applications such as engine exhaust.

Figure 2-9, Full Angle Ring

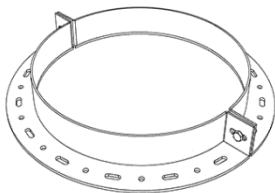

Also see Figures 2-10 and 2-11, the Heavy Duty Base or Wall Brackets may also be used to help support the Full Angle Ring back to the building structure.

Figure 2-10, Heavy Duty Base for Full Angle Ring Example

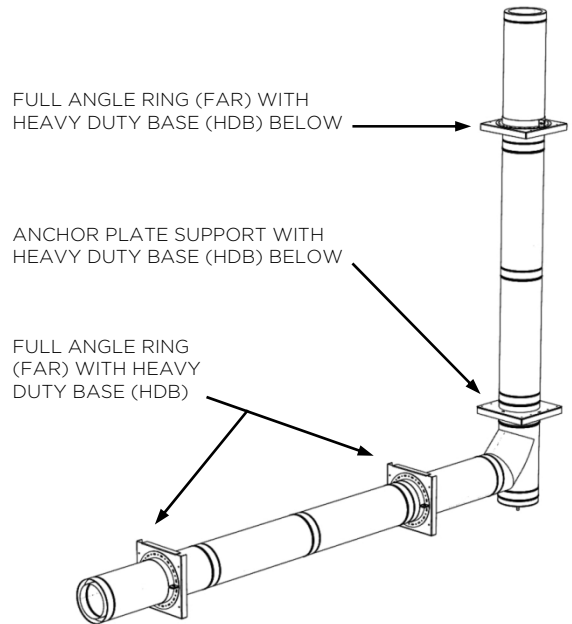
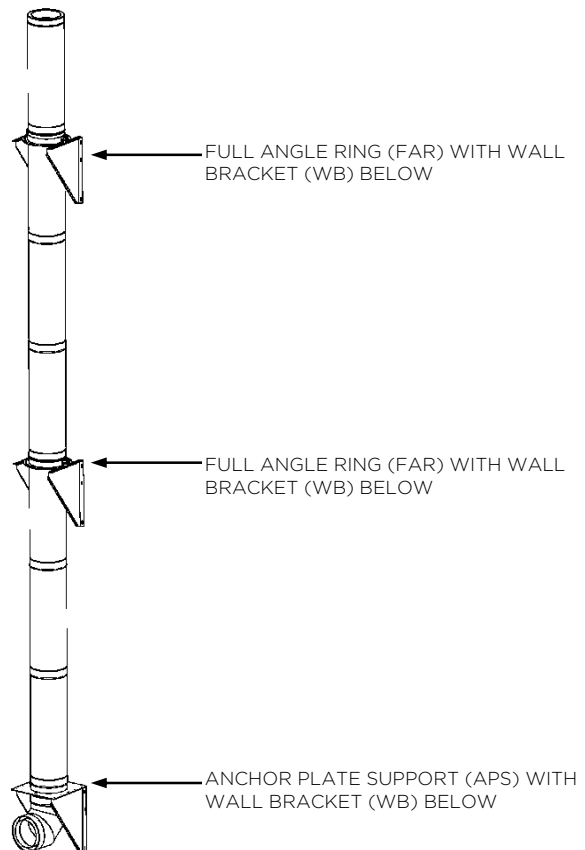

Figure 2-11, Wall Brackets for Full Angle Ring Example



## PART 2 - SUPPORT & GUIDING

### HALF ANGLE RING (HAR)

The Half Angle Ring is used to support/guide horizontal installations and may be suspended by threaded rods. See Full Angle Ring (FAR) for outdoor or vibrating installations.

Figure 2-12, Half Angle Ring

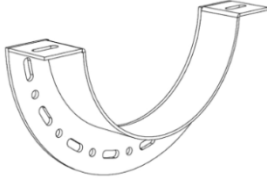

### LIGHT SUPPORT BAND (LSB)

The Light Support Band can be used on low pressure and low temperature applications such as heating boiler stacks and grease ducts (not for use with engine or turbine exhaust) for support/guide in horizontal or vertical installations.

The band firmly clamps around the pipe outer jacket and includes four (4) 1/4" x 20 stainless steel nuts and bolts. Remaining hole in the middle is where wires or threaded rods (by the installing contractor) are used for support or guiding back to the building structure.

Figure 2-13, Light Support Band

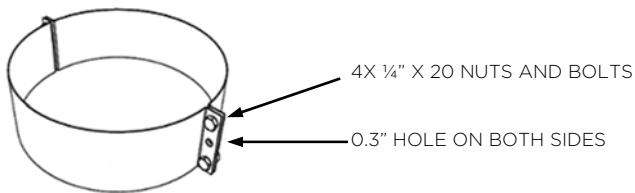
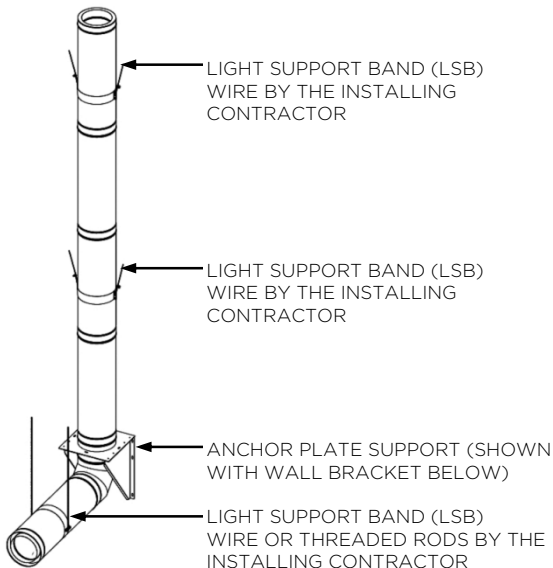

Figure 2-14, Light Support Band Installation Example



### GUY WIRES BAND (GWB)

The Guy Wires Band permits easy connection for three (3) guy wires at 120 degrees apart. The band firmly clamps around the pipe outer jacket and includes three (3) 1/4" x 20 stainless steel nuts and bolts.

The actual guy wires are by others, the structural engineer should select wire size in accordance with good engineering practice to suit each specific application.

Figure 2-15, Guy Wires Band

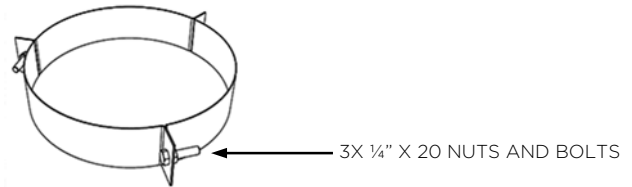
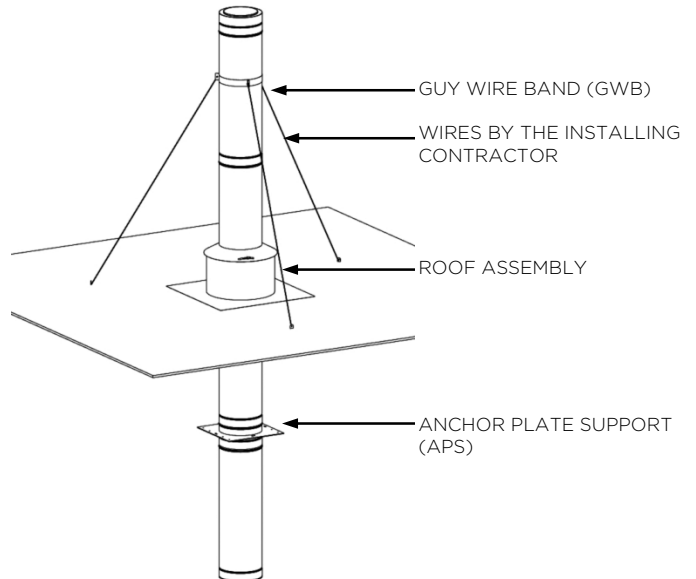

Figure 2-16, Guy Wire Band Installation Example



## PART 3 - PIPE & OTHER LENGTHS

### 9", 12", 18", 24", 30", 36", 42", & 48" FIXED PIPE LENGTHS ( \_L)

Model DWKL have various fixed lengths of pipe.

Any custom length may be ordered from Jeremias Inc.

Figure 3-1, Fixed Pipe Lengths

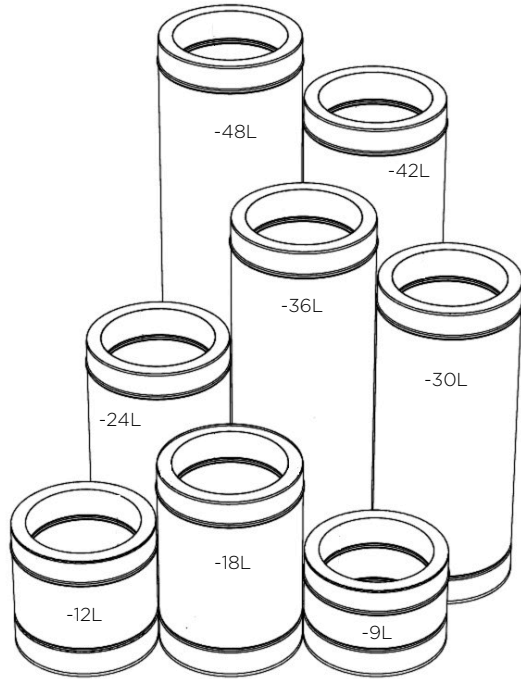

### TEST/NOZZLE PORT LENGTH (TPL)

A Test/Nozzle Port Length can be used for monitoring flue gases, horizontal Grease Duct drain, or implementing internal cleaning equipment inside the pipe. Standard is one 1" NPT nipple, but any size can be factory installed and in multiple configurations.

All ports are continuously welded to the inner pipe. Gaskets or sealant used to connect other equipment and supporting of this equipment is by others.

Figure 3-2, Test/Nozzle Port Section

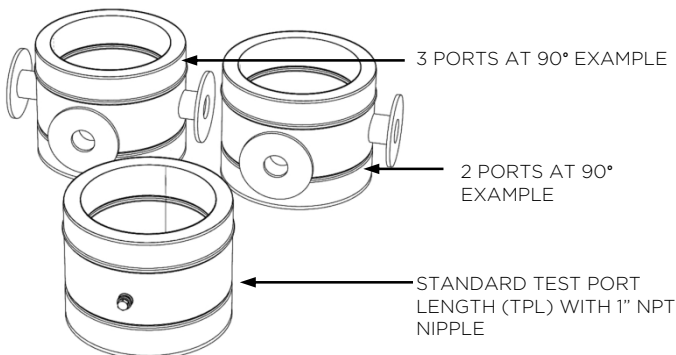

### INLINE ACCESS DOOR LENGTH (IAD)

The Inline Access Door is for the Grease Duct application and provides an easy and no-tool access to the inside exhaust for cleaning and inspection. The Inline Access Door ships fully assembled and no modifications are required in the field.

To open the door, and gain access to the Grease Duct, follow these steps:

- 1) Unlatch the outer jacket clips and open the door (hinges are on the opposite side of the clips).
  - 2) Remove the precut insulation blanket.
  - 3) Loosen and remove the wing nuts.
  - 4) Remove the inner door.
  - 5) Access the Grease Duct.
- Reverse the steps to close the door.

Figure 3-3, Inline Access Door

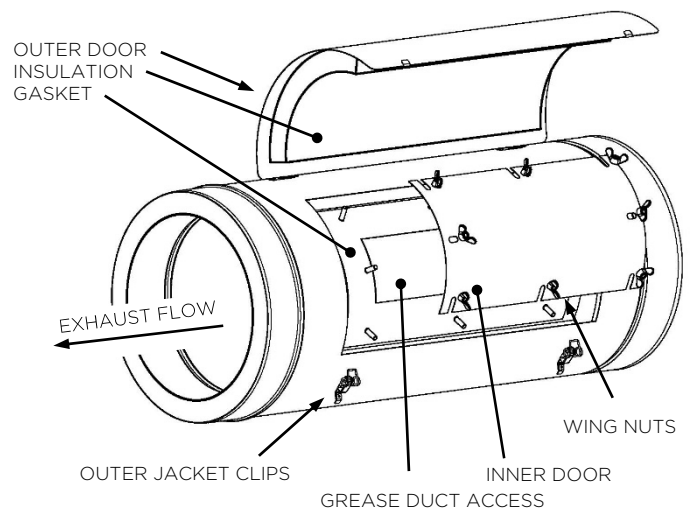

## PART 3 - PIPE & OTHER LENGTHS

### 18" & 30" CUT PIPE LENGTHS (CL)

Cut Pipe Lengths are specifically engineered to be field cut to desired length. This permits the greatest flexibility for complicated installations.

- The minimum installed length of 18CL and 30CL is 5.3".
- The maximum installed length of the 18CL is 15.8".
- The maximum installed length of the 30CL is 27.8".

Cut Pipe Lengths are used in all applications and have been evaluated by UL and confirmed suitable for positive internal pressures up to 60" W.C. (15000 Pa).

**IMPORTANT:** Proper installation of the Cut Pipe Length involves a procedure of very careful measurement and cutting (either in the field or shop) of the outlet end(s) of the Cut Pipe Length with appropriate equipment and technique to achieve a clean, burr free, straight end(s). Experienced sheet metal tradesmen are familiar with such equipment and techniques and should be used for such purpose.

Examples of equipment commonly used for such purpose include:

Type 27 Right Angle Grinder Cutting Wheels for stainless steel and NOGA Model DB1000 double edge deburring tool for thin sheet metal.

Figure 3-4, Cut Pipe Length Installation

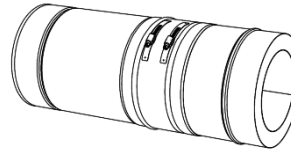
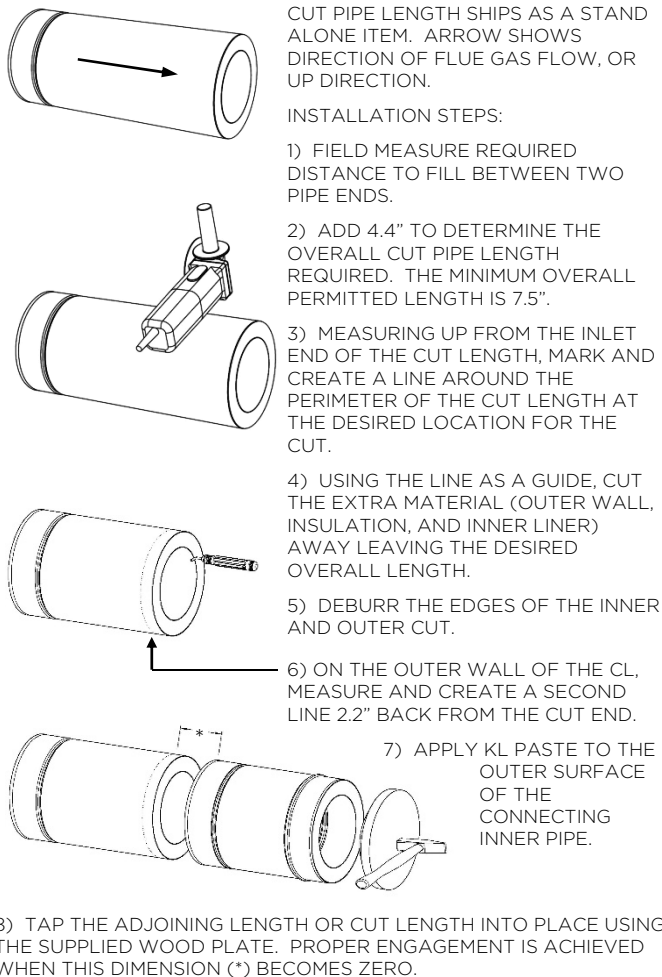

9) INSTALL THE LOCKING BAND (LB) FROM THE ADJOINING PIPE SECTION OVER THE FIELD CUT JOINT LOCATION.

Figure 3-5, Cut Pipe Length Joint Detail

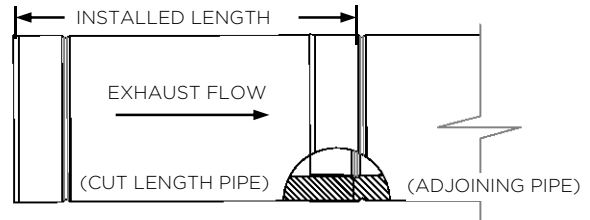

SEE BELOW FOR DETAILED VIEWS OF THE JOINT ASSEMBLY.

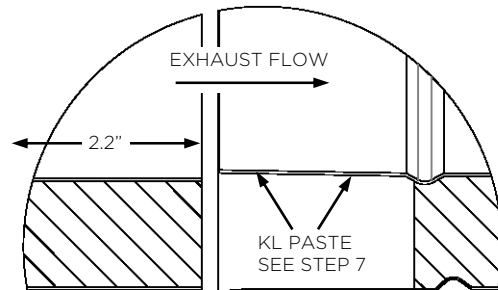

MARK 2.2" FROM THE END OF CUT BEFORE BEING INSERTED INTO THE CONNECTING PIPE CONICAL INLET.

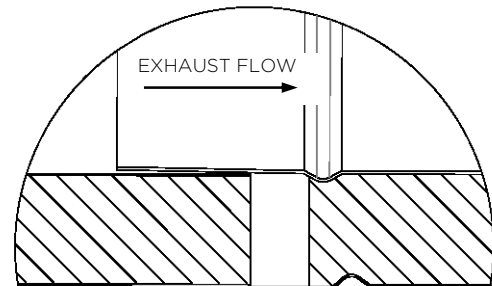

CUT END STARTS TO ENGAGE AT 1.2" INTO OTHER PIPE.

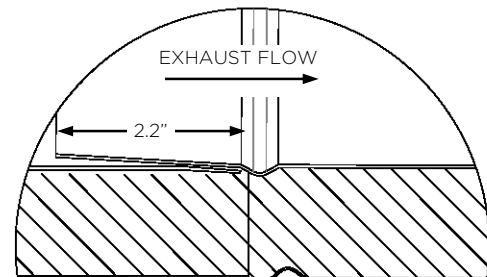

CUT END IS FULLY ENGAGED (2.2") BY TAPPING THE PIPES TOGETHER UNTIL THE OUTLET END OF THE CUT LENGTH IS FULLY ENGAGED (CREATING A TIGHT SEAL) INTO THE CONICAL INLET OF THE CONNECTING PIPE. FOR DWKL THIS OCCURS WHEN THE OUTER WALL OF THE CONNECTING PIPE ENGAGES TO THE CUT LENGTH OUTER WALL LINE CREATED IN STEP 6.

LOCKING BAND IS NOT SHOWN FOR CLARITY.

## PART 3 - PIPE & OTHER LENGTHS

### LENGTH FOR THERMAL EXPANSION

Model DWKL assembled lengths act like a continuous steel pipe, so thermal expansion must be compensated for between anchored or fixed supports. The inner is permitted to expand a greater length than the outer jacket as there are no fixed steel connections between the inner and outer.

Any expansion of the inner in excess of 0.375" (9mm) requires the Adjustable Length with Graphite Packing (18ALG or 30ALG) between fixed anchor points.

### 18" & 30" ADJUSTABLE LENGTHS W/ GRAPHITE PACKING (ALG)

Adjustable Lengths with Graphite Packing have two functions: to serve as an expansion joint and to make up for a required odd length. The adjustable length incorporates a telescoping inner liner that accommodates thermal expansion in longer runs of pipe. It telescopes into a larger diameter stationary length and is sealed by a heavy gage clamp/graphite packing sealing system. It is finished off with a clam shell outer jacket.

Adjustable Lengths ship completely assembled at the "maximum Installed Length" shown herein, and no modifications are required in the field when used only as an expansion joint.

When also using the Adjustable Length to make up for an odd length, you must remove the outer jacket and loosen the clamp/graphite seal to allow the telescoping inner to easily slide further into the stationary length. The insulation may need to be trimmed back also. Tighten the sealing system back in place.

To assure correct engagement of the inlet and outlet ends, the Adjustable Length must be installed to the connecting pipe or fitting while the graphite seal is tightened (either before loosening as the adjustable ships or after tightening when used to make up an odd length).

The Adjustable Length with Graphite Packing has been evaluated by UL and confirmed suitable for positive internal static pressures up to 8" WC (2000 Pa).

Figure 3-6, ALG Adjustable Length Model DWKL Assembly

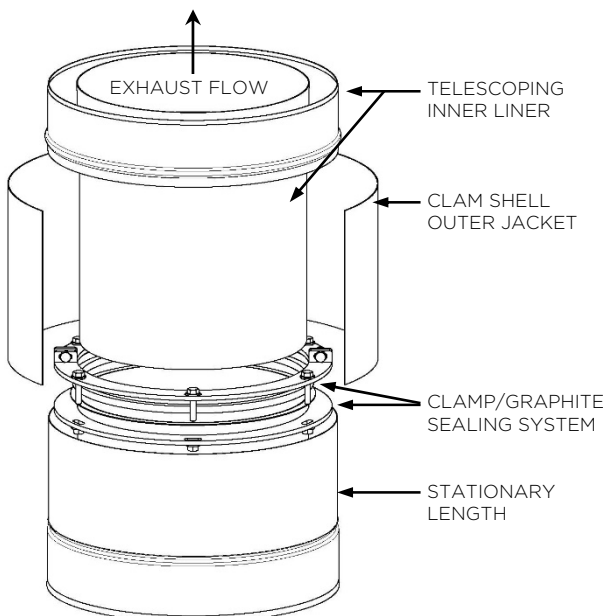

INSTALL\_MF 2015-12-6

Figure 3-7, Adjustable Length Clamp/Graphite Sealing System Detail

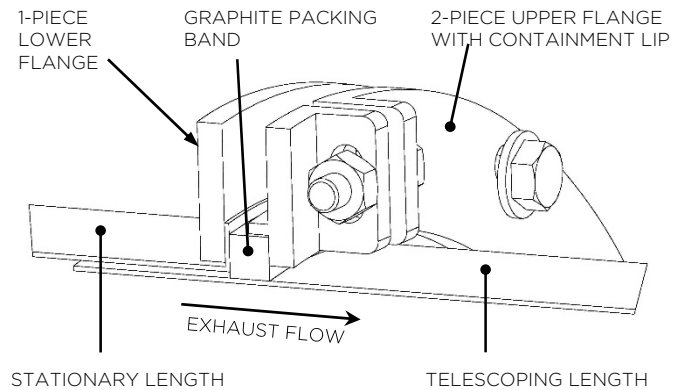
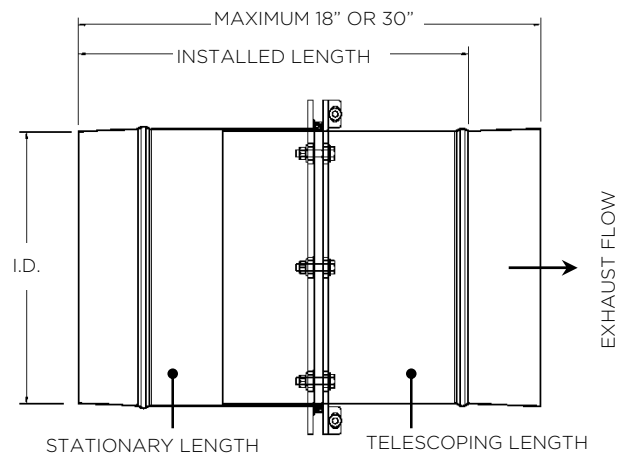

Figure 3-8, 18" & 30" ALG Adjustable Length Dimensions



- The minimum Installed Length of the 18ALG is 11.6"
- The maximum Installed Length of the 18ALG is 15.8"
- The minimum Installed Length of the 30ALG is 15.8"
- The maximum Installed Length of the 30ALG is 27.8"

The above figure shows inner liner only.

Do NOT extend the telescoping inner outwards further away from the stationary length than the above "maximum Installed Length".

In horizontal Adjustable Length installations, add guides near each end to assure correct alignment at all times. In vertical installations, place the Adjustable Length just below a Support as the Adjustable Length is not load bearing.

# PART 4 - FITTINGS, TEE CAPS, & INCREASERS

## SPECIAL CONSIDERATION FOR INSTALLING FITTINGS

When tapping the pipe length into the fitting, 2<sup>nd</sup> person must hold the fitting in place from behind.

Figure 4-1, Special Consideration for Fittings

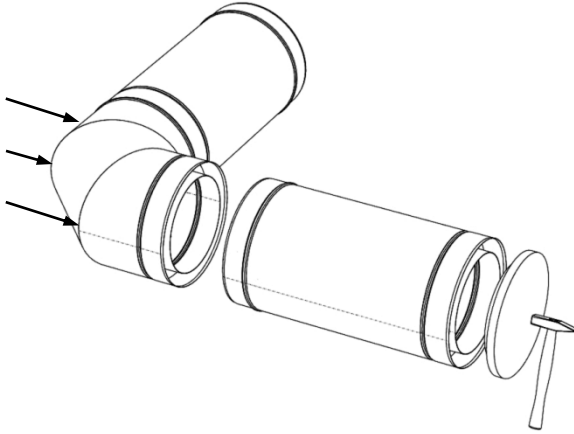

## 87° & 90° BOOT TEE (\_\_BT)

Jeremias Boot Tees offer the added 45-degree gore that directs the flue gases towards the outlet at a 45-degree angle. Most others still allow the flue gases to enter the outlet branch at 90-degrees. Snout can be same or any size smaller than the body.

Figure 4-4, 87° & 90° Boot Tee (\_\_BT)

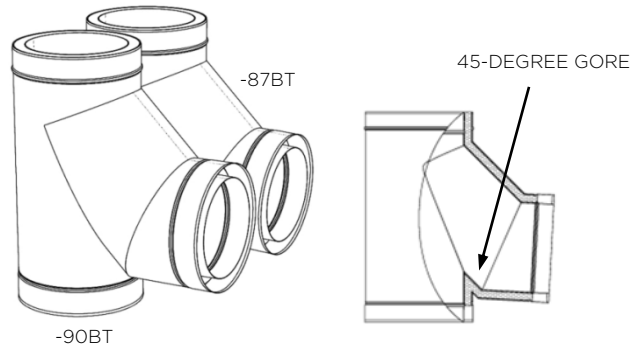

## 1.5°, 3°, 15°, 30°, 45°, 70°, 87°, & 90° ELBOW (\_\_EL)

Elbows may be used singular or in combination to provide changes in direction.

Figure 4-2, 1.5°, 3°, 15°, 30°, 45°, 70°, 87°, & 90° Elbows

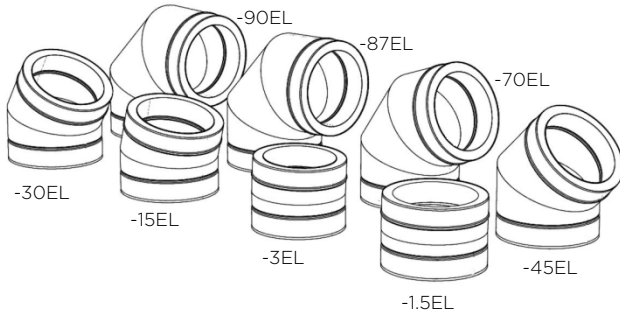

## GREASE DUCT TEE (\_\_GT & \_\_GBT)

Grease Duct Tee fittings have a reversed snout that permits accessibility for cleaning. This is available in every tee option, the arrows below dictate exhaust flow.

Figure 4-5, 45°, 87°, & 90° Grease Duct Tee

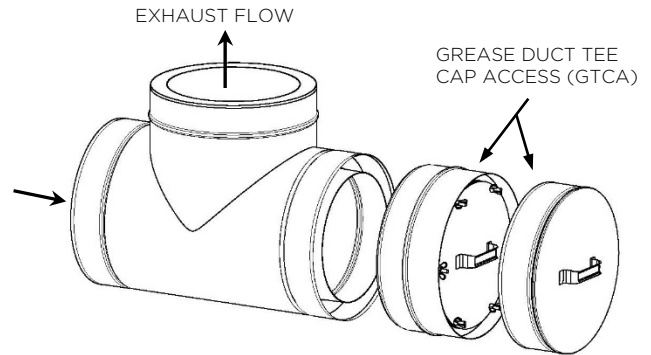

## 45°, 87°, & 90° TEE (\_\_T)

Used as a manifold entry Tee, offset with one of the access cap options, or base Tee with one of the drain tee caps options. Snout can be same or any size smaller than the body.

Figure 4-3, 45°, 87°, & 90° Tees

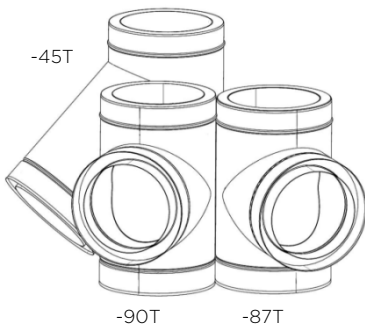
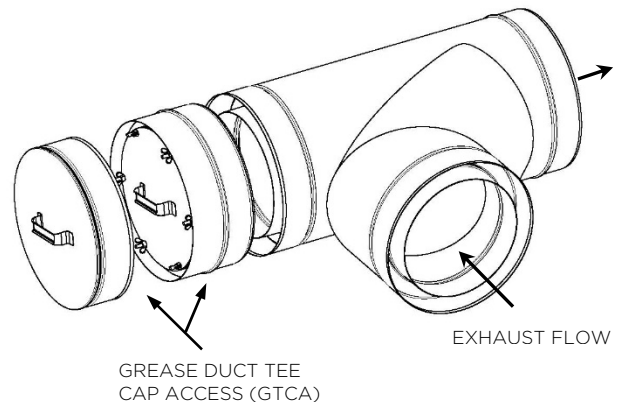

Figure 4-6, 45°, 87°, & 90° Grease Duct Boot Tee



## PART 4 - FITTINGS, TEE CAPS, & INCREASERS

### 45° DOUBLE TEE (45DT)

Used as a two-way manifold entry Tee, offset with one or two of the access cap options, or base Tee with one of the drain tee caps options. Snouts can be any size smaller than the body.

Figure 4-7, 45° Double Tee

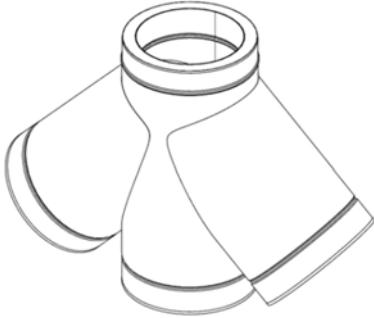

### 90° WYE TEE (90WT)

Used for two-way entries where a tee cap or access cannot be used due to the application or as a 90° that can have an access cap at the middle.

Figure 4-8, 90° Wye Tee

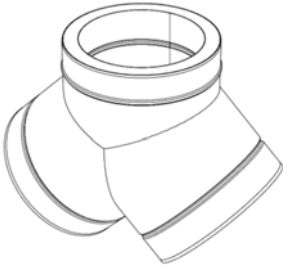

### DRAIN TEE CAPS (DCB & DCS)

Two styles of Drain Tee Caps are available. Each includes a 1" NPT Nipple for a drain line attachment by the installing contractor.

The DCB (B for Bottom) has the nipple at the base. The DCS (S for Side) has the nipple on the side which is convenient in certain applications where the horizontal appliance outlet is very low to the floor.

Figure 4-9, Drain Tee Caps

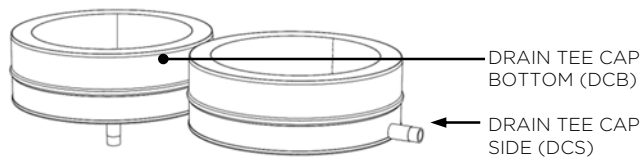

### TEE CAP ACCESS (TCA)

Tee Cap Access permits access to the inside Chimney for inspection and/or cleaning. It can be placed at the end of a snout of any three or four-way fitting. This part is for Chimneys only, use the below Grease tee Cap Access for Grease Ducts.

Gasket and hardware are included so that the internal cap may be removed and reinstalled without tools.

Figure 4-10, Tee Cap Access

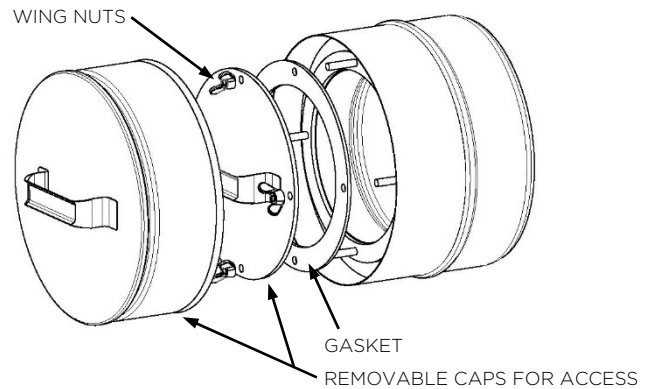

### GREASE TEE CAP ACCESS (GTCA)

Grease Duct Tee Cap Access permits access to the inside Grease Duct for inspection and/or cleaning. It can be placed at the end of a snout of any three or four-way fitting and incorporates a 1½" tall dam to prevent liquid or grease from dropping out when opening.

Gasket and hardware are included so that the internal cap may be removed and reinstalled without tools.

Figure 4-11, Tee Cap Access

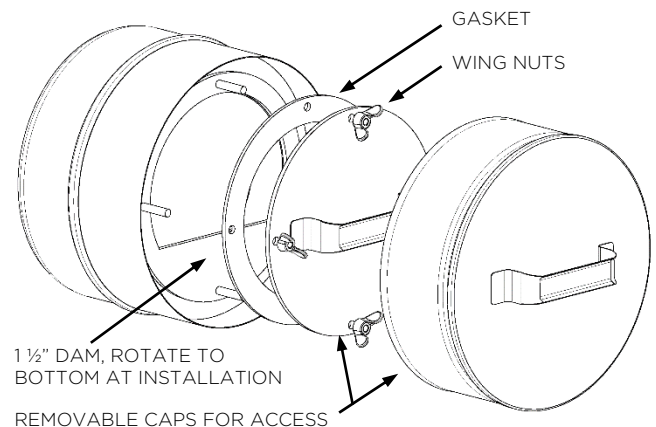

## PART 4 - FITTINGS, TEE CAPS, & INCREASERS

### INCREASERS AND REDUCERS

Reduction fittings are typically used in manifold applications when needed. There are many options for increasers and reducers.

### TAPERED INCREASER & REDUCER (TI & TR)

Tapered Increasers and Reducers keep the same centerline.

Be cautious of using these in the horizontal, due to increased or decreased diameter changes this will cause a low point in the exhaust where condensate can trap. Use the Eccentric increaser and reducer in horizontal installations instead.

Figure 4-12, Tapered Increaser and Reducer

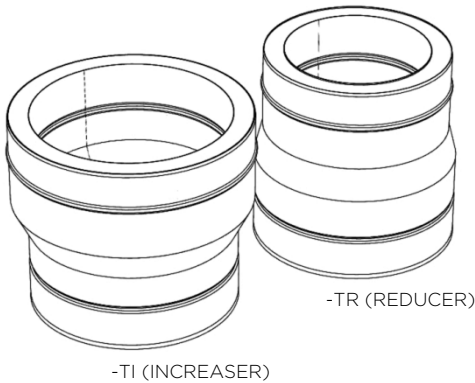

### STEPPED INCREASER & REDUCER (SI & SR)

Stepped Increasers and Reducers can be used in tight situations and are available in all steps.

The Stepped Increasers and Reducers are non-structural parts and must not be subject to loads in either the axial or lateral directions.

Be cautious of using these in the horizontal. Increased or decreased diameter changes will cause a low point in the exhaust where condensation can trap. Use the Eccentric increaser and reducer parts in horizontal installations instead.

Figure 4-14, Stepped Increaser & Reducer

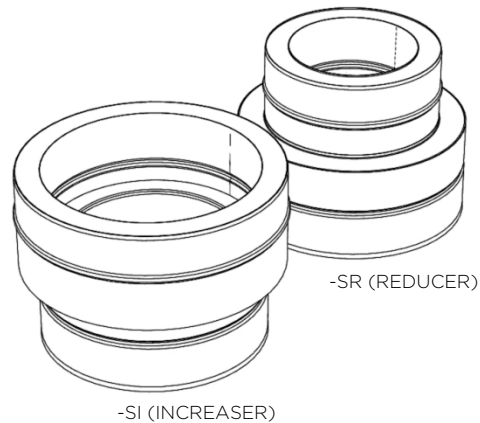

### TAPERED ECCENTRIC INCREASER & REDUCER (TEI & TER)

Tapered Eccentric Increasers and Reducers keep the same low point, or are flat on bottom. They also create a slight centerline offset if used in the vertical installation.

Figure 4-13, Eccentric Increaser and Reducer

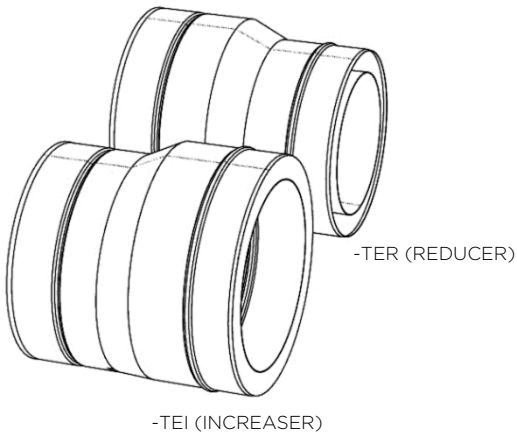

### STEPPED ECCENTRIC INCREASER & REDUCER (SEI & SER)

Stepped Eccentric Increasers and Reducers can be used in tight situations and are available in all steps.

The Stepped Eccentric Increasers and Reducers are non-structural parts and must not be subject to loads in either the axial or lateral directions.

Figure 4-15, Stepped Eccentric Increaser and Reducer

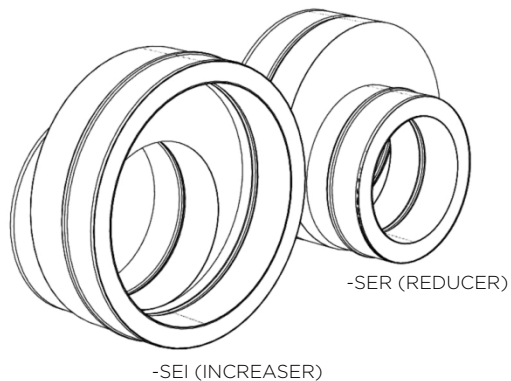

# PART 5 - ADAPTERS & TERMINATIONS

## START & END ADAPTERS

Since Model DWKL is directional with flow, both START and END adapters are typically used in every application.

The Jeremias 2000°F rated gasket used in the Kitchen Inline Access Door KIAD (see Part 3) and Tee Cap Access TCA (see Part 4) may also be used to seal Grease Duct connections to Type I Hoods as detailed in NFPA-96 "Permitted Duct-to-Hood Collar Connection".

## RAW COLLAR ADAPTER (INSIDE) START & END (RCIS & RCIE)

Connects Models DWKL to a nominal collar via flashing inside the appliance collar. Has a support clamp around the outside that rigidly holds the adapter in place. Use approved sealant for gas tight connection.

Figure 5-1, Raw Collar Adapter (Inside) Start & End

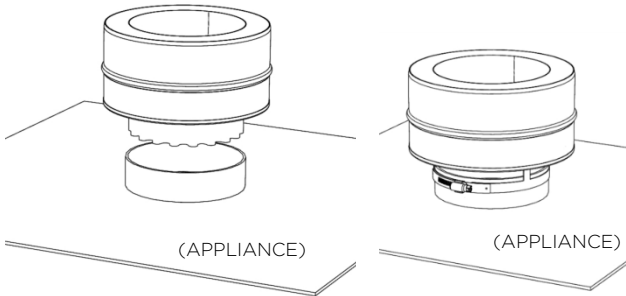

## RAW COLLAR ADAPTER (OUTSIDE) START & END (RCOS & RCOE)

Connects Models DWKL to a nominal collar on the outside of the appliance collar. The adapter is split and uses hardware to tighten against the outside of the collar. Use approved sealant for gas tight connection.

Figure 5-2, Raw Collar Adapter (Outside) Start

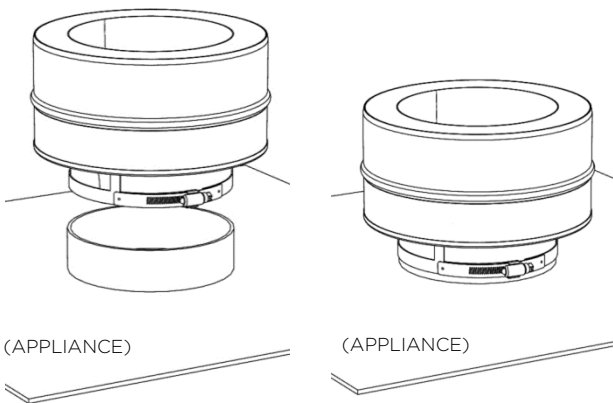

## FLANGE COLLAR ADAPTER START & END (FCS & FCE)

Connects DWKL to any 1/2" flange, typical for many accessories and oven connections. An optional vee band may be added to secure the flange in place.

Table 5-3, Flange Collar Adapter with Optional Vee Band

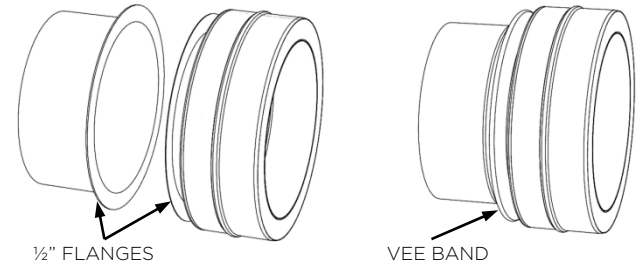

## TRANSITION TO ROUND START & END (TRS & TRE)

Used to connect to and from rectangular or square outlets on kitchen exhaust hoods, fans, or auxiliary equipment. Transitions are custom made to order for project requirements.

The rectangular or square base can be made in accordance with NFPA-96 no-weld hood connection, or may be field welded by the installing contractor. See part 1 "Interconnection with Field Welded Grease Ducts".

Figure 5-4, Transition to Round Start & End

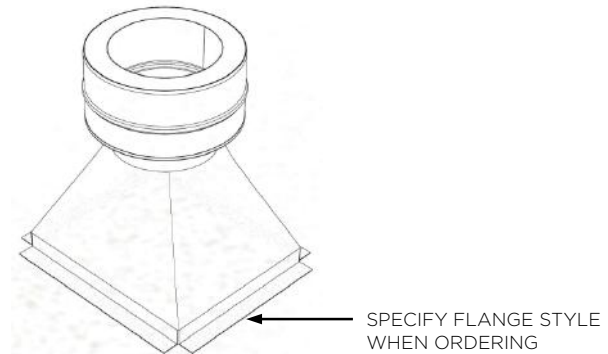

## FAN PLATE ADAPTER START & END (FPS & FPE)

This is a heavier gauge flat plate that can be used to start at a masonry fireplace outlet, or to attach a chimney fan or fan curb housing at the termination.

When used as a Fan Plate Adapter End (as shown in below Figure 5-7), the flat plate is designed to set directly on top of the roof curb (by others). The installing contractor uses bolts or screws through the plate into the curb.

## PART 5 - ADAPTERS & TERMINATIONS

Figure 5-5, Fan Plate Adapter End

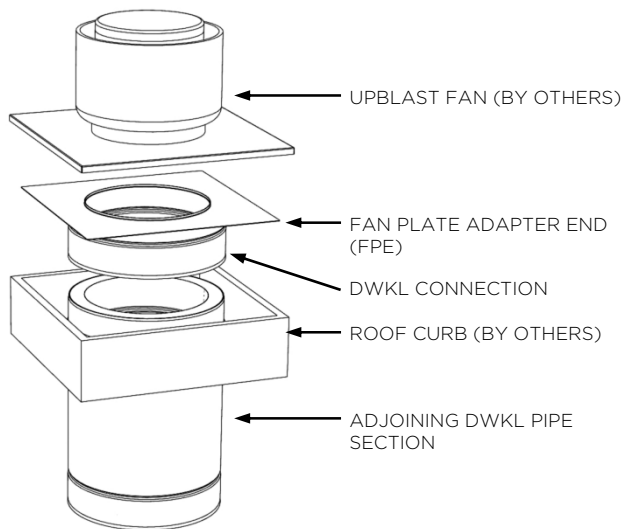

### OPEN TERMINATION (OTN, OTNH, OTS, & OTSH)

An Open Termination that is unrestrictive. Used in both vertical and sidewall scenarios. For Chimney applications, use the Universal Drain Length (UDL) or Drain Tee Cap (DCB or DCS) below to drain rainwater from the exhaust.

The open Termination connects to the Model DWKL pipe using a standard Locking Band (LB)

Figure 5-9, Open Termination

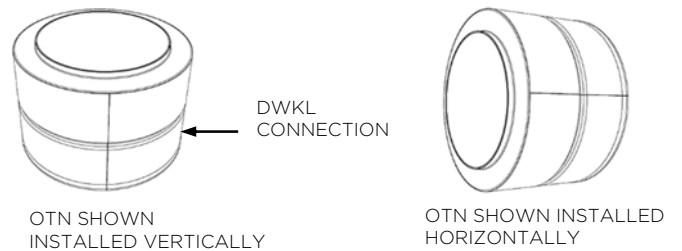

### TERMINATIONS

See GENERAL INFORMATION for termination height above roof requirements.

There are two options to most terminations:

- 1) No Screen (N) or With Screen (S)
- 2) Low Temperature or High (H) Temperature

Jeremias uses 1" x 1" x 0.059" thick stainless steel wire mesh for termination screens. The purpose of a screen is to not allow debris or personnel into the exhaust and also used to restrict rodents or birds from entering the exhaust.

Model DWKL inner pipe will expand to a much greater length than the outer jacket. Some terminations are purposely designed to compensate for this expansion. Low temperature means any application that would have less than 1/2" expansion. High temperature means where expansion could be more than 1/2" but not greater than 6" of expansion between the inner and outer pipes.

### EXIT CONE (EC & ECH)

The Exit Cone increases velocity by 50%. For Chimney applications, use the Universal Drain Length (UDL) or Drain Tee Cap (DCB or DCS) below to drain rainwater from the exhaust.

The Exit Cone connects to the Model DWKL pipe using a standard Locking Band (LB).

Figure 5-10, Exit Cone

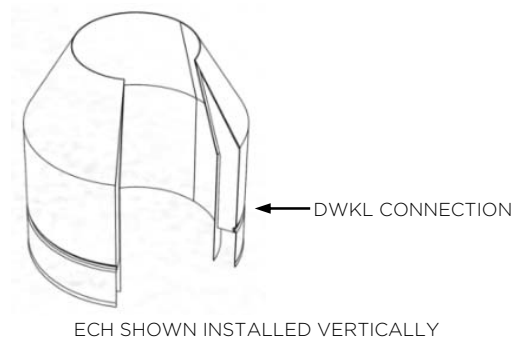

# PART 5 - ADAPTERS & TERMINATIONS

## FLAT TOP RAIN CAP (FTN, FTNH, FTS, & FTSH)

A basic flat top rain cap.

Part includes an Open Termination (OTN or OTNH) and shipped completely assembled. The top may be field removed if access is required.

The Flat Top Rain Cap connects to the Model DWKL pipe using a standard Locking Band (LB).

Figure 5-11, Flat Top Rain Cap options

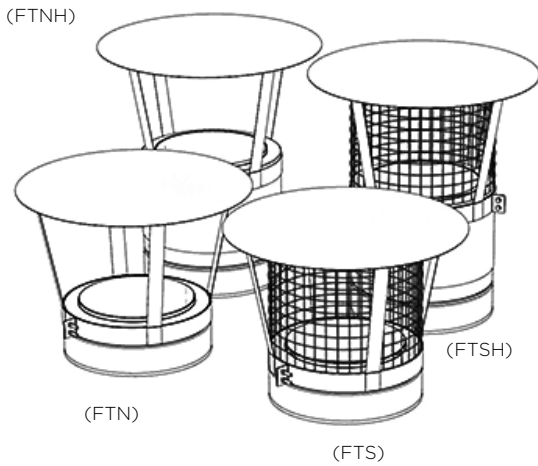

## STACK CAP (SCN, SCNH, SCS, & SCSH)

An ASHRAE style of rain cap, also known as china cap, has an inverted cone to help disperse flue gases and to provide a lower pressure drop.

Part includes an Open Termination (OTN or OTNH) and shipped completely assembled. The top may be field removed if access is required.

The Stack Cap connects to the Model DWKL using a standard Locking band (LB).

Figure 5-13, Stack Cap options

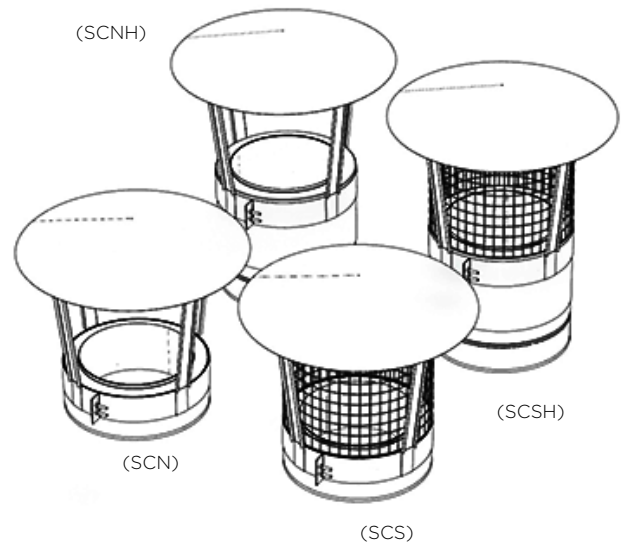

## HIGH WIND RAIN CAP (WRC)

This cap helps to reduce downdraft on gravity equipment and provides best rain protection.

The High Wind cap connects to the Model DWKL pipe using a standard Locking Band (LB).

Figure 5-12, High Wind Cap

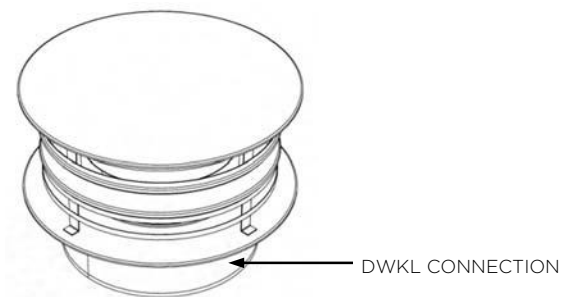

# PART 6 - THIMBLE, FLASHINGS & SHIELD

## THIMBLE & FLASHINGS OPTIONS

Thimble, Flashings and Storm Collars - Use / Selection

- 1) **High Temperature Thimble (HTT)** - Required for all chimney applications passing through combustible roofs.
- 2) **Flat Roof Flashing (FRF)** - For flat roofs. Fits over HTT and used for 1000F max continuous applications. Also permitted for use when the entire roof penetration is non-combustible.
- 3) **Pitched Roof Flashing (PRF)** - For sloped roofs. Fits over HTT and used for 1000F max continuous applications. Also permitted for use when the entire roof penetration is non-combustible.
- 4) **Storm Collar (SC)** - For use with FRF and PRF.
- 5) **Flat Cone flashing (FCF)** - For flat roofs. Permitted for use when the entire roof penetration is non-combustible.
- 6) **Pitched Cone flashing (PCF)** - For sloped roofs. Permitted for use when the entire roof penetration is non-combustible.
- 7) **Storm Collar for Coned Flashings (SCCF)** - For use with FCF and PCF.

## HIGH TEMPERATURE THIMBLE (HTT)

This roof thimble provides safe installation against combustible materials. It is part of the Unvented Roof Assembly (see Figure 6-5).

The thimble is fiber insulated and includes a lateral pipe guide with hardware at the top. The thimble extends down 12" from the installation brackets. Hardware to connect brackets to the roof is not included.

Figure 6-1, High Temperature Insulated Thimble (HTT)

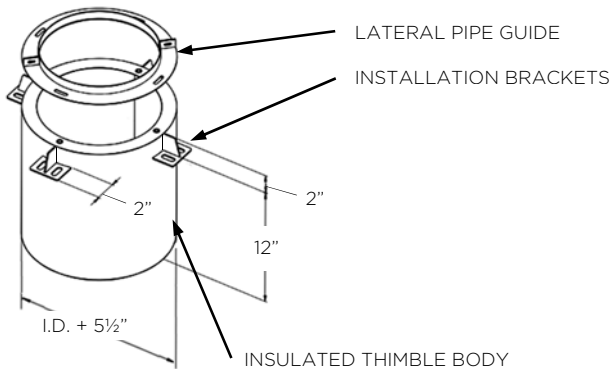
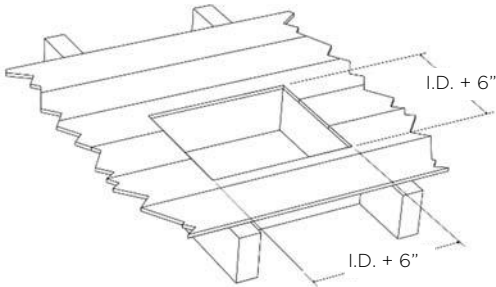

Figure 6-2, Roof Framing for Insulated Thimble



## ROOFS WITH A SLOPE OR PITCH

When using the roof thimble with sloped roof construction, the installing contractor has two choices:

- 1) Fabricate a flat, horizontal curb for installation of the roof thimble shown. The curb extends out from the high side of the roof opening.
- 2) Order a special version of the roof thimble that has the brackets factory installed to match the desired roof pitch.

In all cases, it is important to insure that the thimble body extends down at least 1" past the lowest portion of the roof framing when installed. Thimbles with extended length bodies are available on special request from the factory.

## FLAT & PITCHED ROOF FLASHINGS (FRF & PRF) & STORM COLLAR (SC)

The Flat Roof Flashing and Pitched Roof Flashing can be used for non-combustible construction and also fit over the High Temperature Thimble (HTT) as part of the Roof Assembly with Thimble. The Storm Collar flashes above the roof flashing and is sealed to the outer jacket (but not attached to the flashing permitting expansion).

Figure 6-3, Flat & Pitched Roof Flashing and Storm Collar

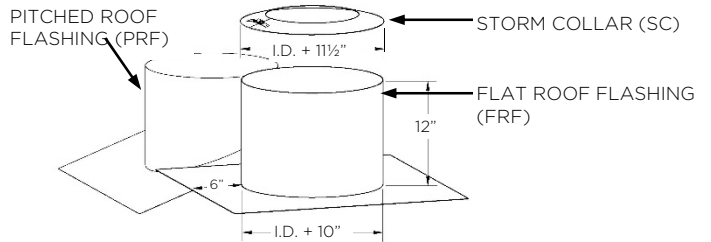

## UNVENTED ROOF ASSEMBLY

For all UL-103 and UL-1978 applications (1000°F maximum continuous temperature), UL has determined the High Temperature Insulated Thimble (HTT) alone, without ventilation, provides a safe installation through a combustible roof or wall. In this manner, the Flat Roof Flashing (FRF) in conjunction with the standard Storm Collar (SC) is used.

Figure 6-4, Unvented Roof Assembly

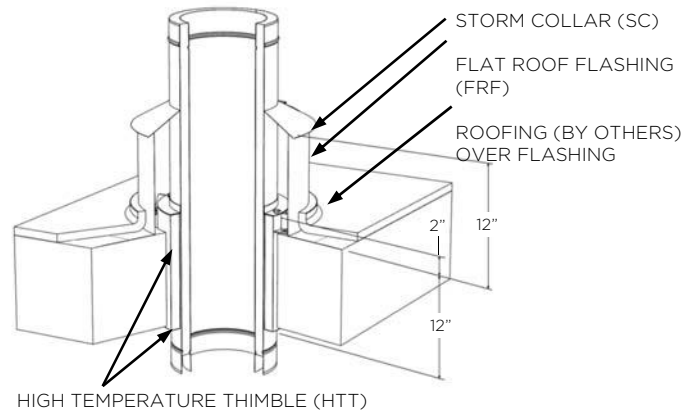

## FLAT & PITCHED CONE FLASHINGS (FCF & PCF) & STORM COLLAR (SCCF)

The Flat Cone Flashing and Pitched Cone Flashing can be used for non-combustible construction. The Storm Collar for Coned Flashings flashes above the Cone Flashings and is sealed to the outer jacket (but not attached to the flashing permitting expansion).

Figure 6-5, Flat & Pitched Cone Flashings and Storm Collar

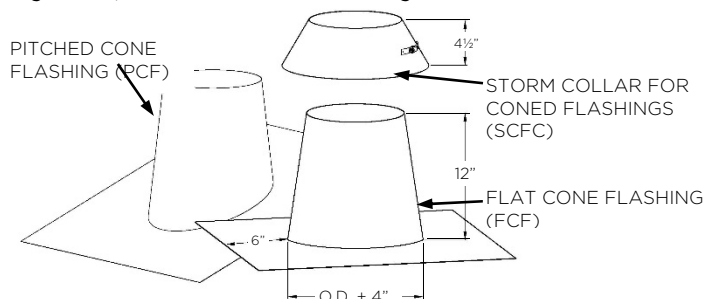

# PART 6.1 - THIMBLE & FLASHINGS

Figure 6-5, Flat & Pitched Cone Flashings and Storm Collar

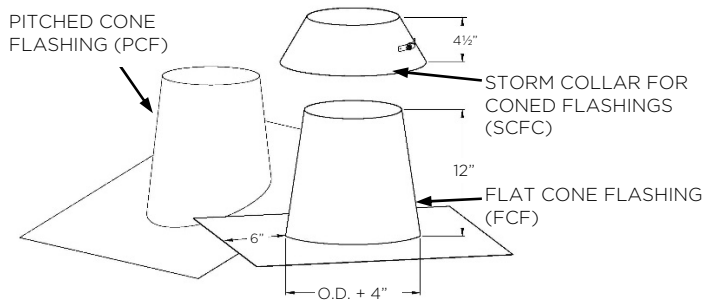

## SIDEWALL THIMBLE (LTT)

This wall thimble provides safe installation against combustibles materials. Only for DWKL use. Noncombustible wall penetrations do not require a thimble.

The LTT thimble is fiber insulated and includes a heavy gage outside wall plate that is welded to the thimble that centers the DWKL pipe. A floating inside plate is also provided to finish the inside wall opening. The Outside Plate is attached to the wall by the installing contractor. Both the outside and inside plates measures 10" larger than the DWKL pipe I.D.

The minimum framed opening is DWKL pipe I.D. plus 6". The maximum wall thickness is 11 1/2".

Figure 6-6, Sidewall Thimble (LTT)

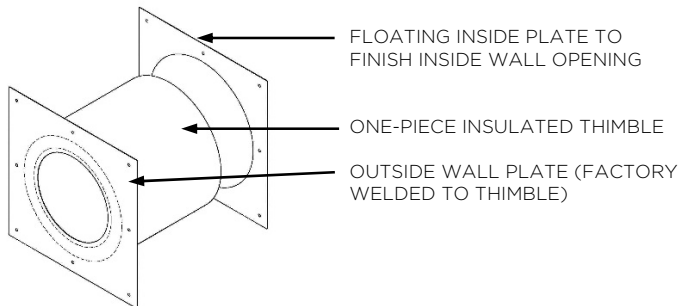
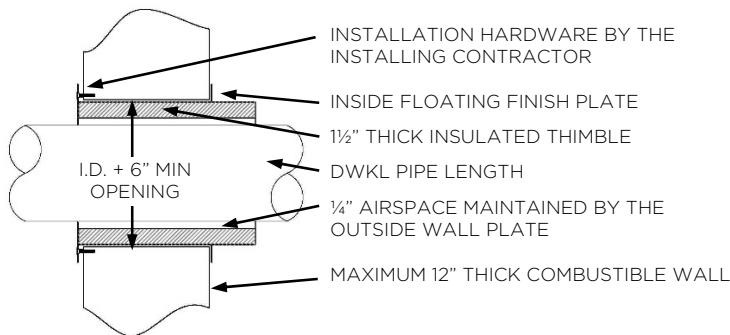

Figure 6-7, Sidewall Thimble (LTT), Installed Cross-Sectional View and Framing Dimension



## WALL THIMBLE (WTS / WTR) FOR 3" & 4" SWKL

This wall thimble provides safe installation against passing through combustible wall for 3" and 4" SWKL for Special Gas / Type BH Vent Applications. Noncombustible wall penetrations do not require a thimble.

WTS has a Square Plate and WTR has a Round plate. The maximum wall thickness is 7".

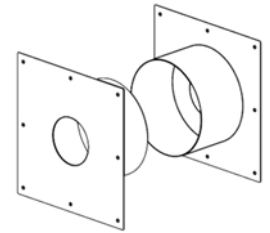
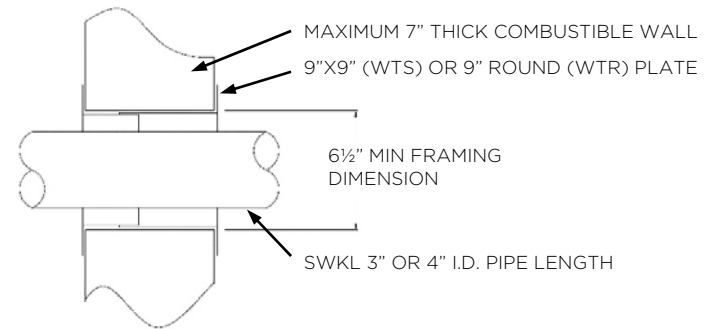

Figure 6-8, Wall Thimble (WT) for 3" & 4" SWKL

Figure 6-9, Wall Thimble (WT) for 3" & 4" SWKL, Cross-Sectional View and Framing Dimension



## FIRESTOP SPACER (FS)

The Firestop Spacer is for use when penetrating a non-fire resistance rated ceiling or floor in installations where a separate fire rated enclosure is not required. Available in all diameters for DWKL, only 3" and 4" diameters of SWKL, and this Firestop is for venting applications only (not for use with UL-103 chimneys). The square plate measures pipe O.D. + 10".

For all diameters of DWKL: Clearances at DWKL firestops are 1" minimum for all "Unenclosed" and "Enclosed" applications.

For 3" and 4" diameters of SWKL: Clearances at 3" and 4" SWKL firestops are per Table 1-4 in Part 1 of these instructions. For "Enclosed" applications in the "Horizontal" configuration, the Wall Thimble (WT) should be used.

Figure 6-10, Firestop

