

Double Axle Trailer



Overview

Marra Forni Double Axle Trailers are the ideal vehicles for mobilizing 130 Neapolitan brick-fired ovens. Each trailer is reinforced with ribs to support the weight of the oven and is built with a flat platform for ample support including an exerted 3 inch wall all around the plate. The trailer allows for wood storage and possible cooler storage. The rear lighting affords optimal flexibility for maneuvering from day to night.

Standard Features

- Key lockable and removable barn doors
- Electric and manual brakes
- 7 RV plug
- Galvanized tongue jack and leveling jacks
- Easy to use clam hitch
- Rubber shock mounted lights
- Marine sealant for seamed sealed joints
- Standard garage size
- Meets required NATM standards
- Exceeds Federal Highway Safety Standard
- Black all frame work on inside
- Three inch tubing top rail on each side

Dimensions

- Overall length: 120"
- Width: 94"
- Height: 43"
- 35 sq. ft. of under oven storage
- Maximum capacity of 5200 lbs

Certifications



Front View

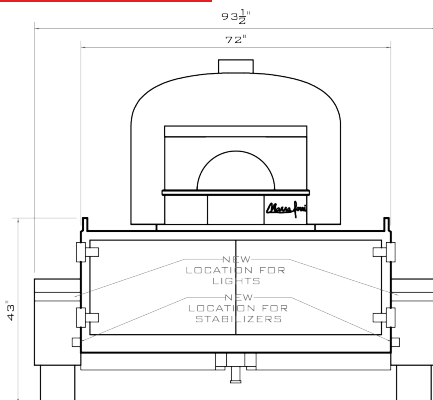

Side View

