

Square Oven 37-25 (MS 37-25W) Wood-Fired Ovens



Overview

Our Square Oven 37-25 is designed specifically to accommodate the high-volume pizza making of a true Pizzaiolo. This model features a 37 inch wide by 25 inch deep deck. The dome and deck consist of refractory bricks with 4 inches of multi-layered insulation in the dome and 8 inches in the deck. The oven features a 26 inch by 9.5 inch opening along with a stainless steel flue collar atop the dome. A round flue adapter comes standard on all ovens.

The oven requires a 2 inch tolerance in all directions, and comes standard with a fire-rated tile clay dome. The Square model also features a 12 inch landing on the opening, as well as a control located between the deck and the top of the dome for getting a precise reading. Oven can be vented directly to the roof or vented through a powered type 1 exhaust hood with approved grease rated duct in accordance with all local and national codes. Wood burning ovens must be vented as a solid fuel burning appliance and must be installed following a manner that obeys all local and national codes and is acceptable to authority having jurisdiction.

Pizza Capacity

Cooking Surface = 6.32 sq. ft.
Pizza Capacity 8" = 11
Pizza Capacity 10" = 7
Pizza Capacity 12" = 4
Pizza Capacity 16" = 1-2

Electric Requirements

120V/ Single Phase / 12 Amps
9 ft. power cable integrated.

Venting

The oven is vented through an 8" round duct collar. The Neapolitan gas ovens can be installed with a listed exhaust hood system or with a direct vent exhaust duct vented outside without an exhaust hood, but must be installed with a power exhausted vent.
Cubic Feet per Minute: 150CFM
Static Pressure: 0.01" W.C.

Standard Features

Touchscreen
Refractory Proprietary Brick Deck
Steel Stand
Door
Powder Coating
Stainless Steel Flue Collar/Adapter
2 Year Deck and Dome Warranty
1 Year Parts and Labor Warranty

Optional Features

Stainless Steel Frame
Stainless Steel Stand
Enclosed Facade
Integrated Exhaust System
Exhaust Fan
Interior Lights
All Fuel Grease Duct
Aluminum Oven Tools
Fan Interlock

Clearance Requirements

2" Minimum clearance for Combustibles on all sides.
0" Minimum clearance for Non Combustibles.

Shipping Dimensions

Actual Weight: 1,774 LBS
Crate Weight: 2,074 LBS
Crate Width: 64"
Crate Depth: 73"
Crate Height: 82"

Certifications



Square Oven 37-25 (MS 37-25W) Wood-Fired Ovens

Plan View

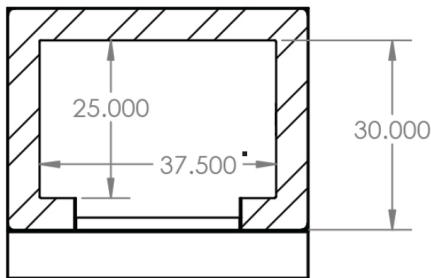

Legend

- C**-Controls
- E**-Electrical Connection Flexible Cord
- F**-Flue Collar
- G**-Gas Connection
- S**-Storage Shelf

Front View

Side View

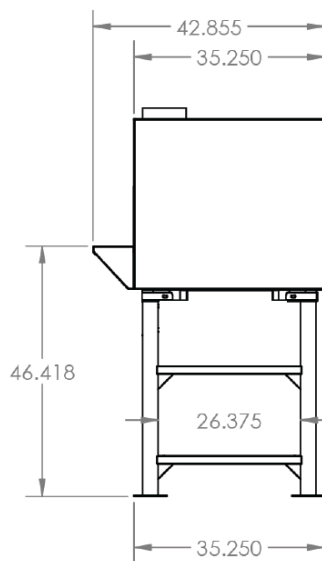
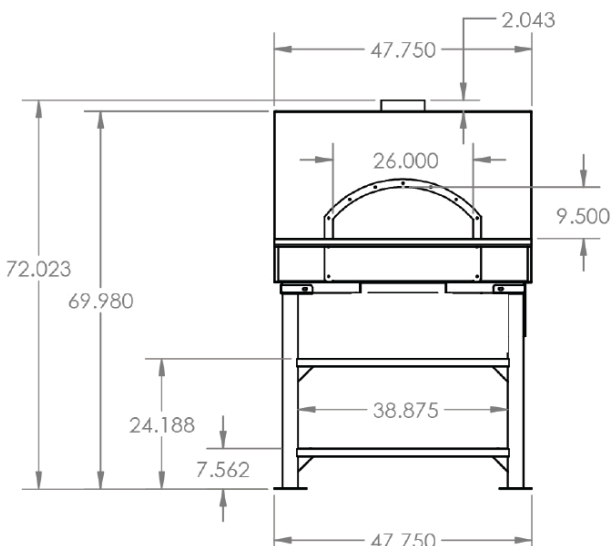

Notes

An ongoing program of product improvement may require us to change specifications without notice.

All ovens are designed to suit commercial usage.

Spec dimensions to be +/- 0.50 inch.

Oven sizes refer to dome interior size.

All Marra Forni ovens are ETL, and VPN approved.

All oven Freight Class 77.5 and must be shipped LTL.

All Marra Forni ovens are approved with a door that is used as a fire suppressor. The door completely closes the front cavity of the oven. Sprinkler/ansul systems not required.

Learn about gas, electrical, venting and clearance requirements at MARRAFORNI.COM

