

Rotator 130 (RT130WG) Wood & Gas Fired Brick Ovens

Overview



Our 130 Rotator Neapolitan model, which is designed specifically to accommodate the high-volume pizza making of a true Pizzaiolo. The 130 features a 51.18 inch deck. The dome and deck consist of refractory bricks with 4 inches of multi-layered insulation in the dome and 8 inches in the deck. The oven features a 26 inch by 9.5 inch opening along with a stainless steel flue collar atop the dome.

The oven requires a 2" tolerance in all directions, and comes standard with a fire-rated tile clay dome. The 130 Rotator Neapolitan model also features a 14 inch landing on the opening, as well as a control located between the deck and the top of the dome for getting a precise reading. Oven can be vented directly to the roof or vented through a powered type 1 exhaust hood with approved exhaust duct in accordance with all local and national codes. Oven must be installed following a manner that obeys all local and national codes and is acceptable to authority having jurisdiction.

Pizza Capacity

Cooking Surface = 14.3 sq. ft.
Pizza Capacity 8" = 12 -14
Pizza Capacity 10" = 10 -12
Pizza Capacity 12" = 7 -10
Pizza Capacity 16" = 5-7

Gas Requirements

Gas connections 3/4" NPT per burner, quick disconnect gas hose must be used. Pressure required 10" - 14" W.C. (Water Column) at the gas valve. 84,000 BTU's per burner.

Electrical Requirements

120V/ Single Phase / 12 Amps
9 ft. power cable integrated.

Venting

The oven is vented through an 8" round duct collar. The Neapolitan wood, gas, and combination gas-wood ovens can be installed with a listed exhaust hood system or with a chimney/grease duct vented outside without an exhaust hood, but must be installed with a power exhausted vent. Cubic Feet per Minute: 150CFM
Static Pressure: 0.01" W.C.

Standard Features

Touch Screen
Dome Terra Cotta Finish
Turbo Burner
Brick Deck
Wood Chamber
Door / Fire Suppressor
Stainless Steel Flue Collar/Adapter
Steel Stand
Powder Coating
2 Year Deck and Dome Warranty

Optional Functions

Custom Tile Applications
Integrated Exhaust System
Exhaust Fan
Stainless Steel Mask / Stand
Enclosed Facade
All Fuel Grease Duct
Gas Burning Accessories
Aluminum Oven Tools
Fan Interlock
Interior Lights

Clearance Requirements

2" Minimum clearance for Combustibles on all sides.
0" Minimum clearance for Non Combustibles.

Shipping Dimensions

Actual Weight: TBD
Crated Weight: TBD
Crated Width: 96"
Crated Depth: 87"
Crated Height: 90"

Certifications



Rotator 130 (RT130WG) Wood & Gas Fired Brick Ovens

Top View

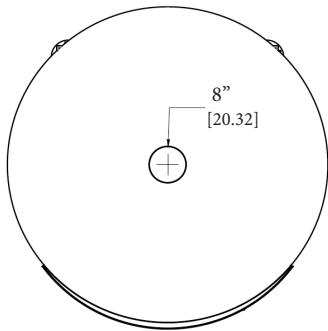

Plan View

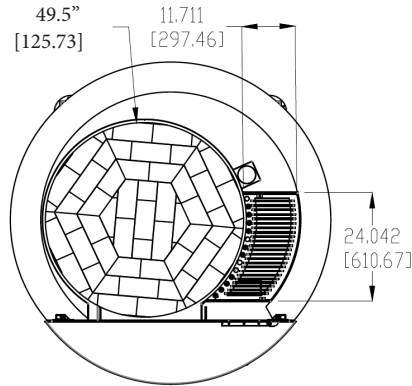

Legend

- C**-Controls
- E**-Electrical Connection Flexible Cord
- F**-Flue Collar
- G**-Gas Connection
- S**-Storage Shelf

Front View

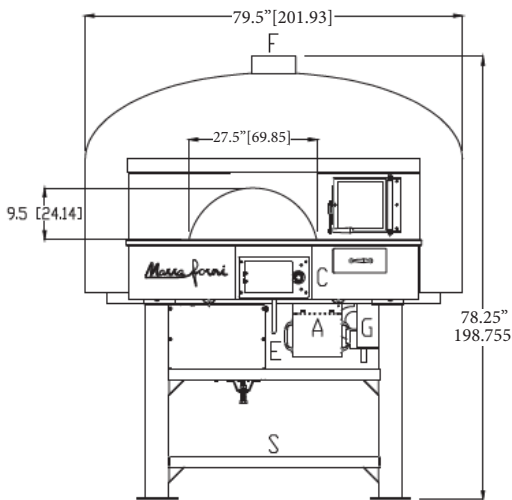

Side View

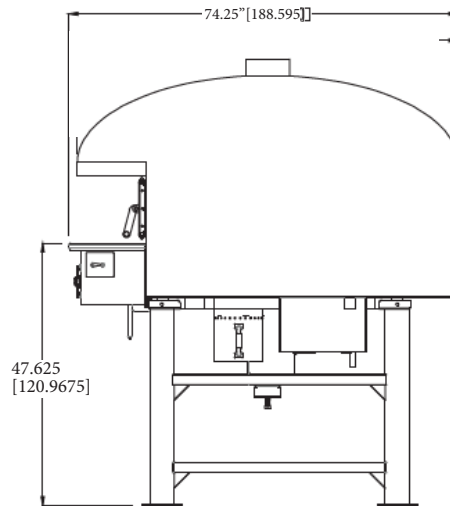

Notes

An ongoing program of product improvement may require us to change specifications without notice.

All ovens are designed to suit commercial usage.

Spec dimensions to be +/- 0.50 inch.

Oven sizes refer to dome interior size.

All Marra Forni ovens are ETL, and VPN approved.

All oven Freight Class 77.5 and must be shipped LTL.

All Marra Forni ovens are approved with a door that is used as a fire suppressor. The door completely closes the front cavity of the oven. Sprinkler/ ansul systems not required.

Learn about gas, electrical, venting and clearance requirements at MARRAFORNI.COM

