

Owner's Manual

THE ROTATOR

Marra forni[®]
Brick Oven Cooking Solutions

10310 Southard Drive | Beltsville, MD 20705 | www.marraforni.com | 888.239.0575

DO NOT THROW THIS MANUAL AWAY.
REVIEW WARRANTY BEFORE INSTALLING OVEN.

WARNING! WHEN CURING OVEN, REMOVE FIRE SUPPRESSION DOOR.

Manual Contents

UL, CSA, ETL & CE FACT SHEET.....	4
Warnings.....	5
Lifting and Moving Your Oven.....	6
Clearances and Requirements.....	7
Oven Installation.....	8
Direct Venting.....	10
Ventilation Requirements	11
Gas Installation.....	12
Gas Specifications.....	13
Guidelines for Oven Use.....	14
Operation Instructions.....	15
Controller Console - Default Screen.....	16
Controller Console - Language, Time, and Date Setup.....	17
Intro to Curing.....	18
Controller Console - Start Curing Process.....	19
Controller Console - Confirm Curing.....	20
Controller Console - Curing: Day 1 - 5.....	21
Controller Console - Select Mode.....	22
Controller Console - Default Recipe.....	23
Controller Console - User Recipe.....	24
Controller Console - Manual Mode.....	27
Specifications.....	28
Electrical Specifications.....	29
Daily oven Operation	32
Burner Clean out	33
Troubleshooting.....	34
Troubleshooting Chart and Recommendations.....	35
Ignition Control Troubleshooting Flowchart.....	36
Gas Burner Parts.....	37
Oven Fan.....	38
Warranty.....	41

UL, CSA, ETL & CE FACT SHEET ▶

Marra Forni products that feature these logos meet rigorous standards for electrical safety and electromagnetic emissions. The acronyms are as follows:

UL: Underwriters Laboratories, Inc.

CSA: Canadian Standards Association

ETL: Formerly ETL Testing Laboratories, now Intertek Testing Services

CE: Conformance European

Underwriters Laboratories, Inc. is an independent nonprofit organization that tests products for safety and certifies them. UL has developed more than 800 standards for safety, and millions of products and their components are tested to UL's safety standards. If a Marra Forni product is UL listed, you know it has passed UL's stringent tests for electrical safety. UL's web site can be found at <http://www.ul.com>.

The Canadian Standards Association is a nonprofit association serving business, industry, government and consumers in Canada as well as the global marketplace. Along with their other duties, CSA develops standards that enhance public safety. A Nationally Recognized Testing Laboratory (NRTL), CSA also familiarizes themselves with U.S. requirements. According to OSHA regulations, the CSA-US mark qualifies as an alternative to the UL mark. The ETL mark is an alternative to both the CSA and UL marks.

Intertek Testing Services, formerly known as ETL, has been conducting electrical performance and reliability tests since 1896. Intertek Testing Services acquired ETL in 1996. ITS is recognized by OSHA as a Nationally Recognized Testing Laboratory, just like UL, CSA and several other independent organizations. ITS tests products according to nearly 200 safety and performance standards. The ETL listed mark and C-ETL listed mark are accepted throughout the U.S. and Canada when denoting compliance

with nationally recognized standards such as ANSI, IEC, UL and CSA. This mark indicates that the product has been tested to and has met the minimum requirements of a widely recognized (consensus) U.S. product safety standard, that the manufacturing site has been audited, and that the applicant has agreed to a program of periodic factory follow-up inspections to verify continued conformance. If the mark includes a small "US" or "C," it follows product safety standards of the United States and/or Canada, respectively.

The European Commission describes the CE mark as a "passport" that allows manufacturers to circulate industrial products freely within the internal market of the European Union. The CE mark certifies that the products have met E.U. health, safety and environmental requirements that ensure workplace and consumer safety. All manufacturers in the E.U. and abroad must affix the CE mark to those products covered by the "New Approach" directives in order to market their products in Europe. Once a product receives the CE mark, it can be marketed throughout the E.U. without undergoing further modification. An important document related to CE is the Declaration of Conformity (DOC). It is a statement that a company authority must sign to say that their device meets the requirements of the directive. The DOC must include a list of any standards used to justify the claim of compliance with the directive.

If a Marra Forni product is stamped "CE," the product does not emit excessive radiation (microwave or RF), and is not overly sensitive to picking up radiation. In summary, the certification marks on our products are your assurance that the product meets rigorous standards for electrical safety and electromagnetic emissions. It poses no shock hazard (except as noted on the product or manual), and it will not cause EM interference with other devices beyond a certain distance.

Thank You for Purchasing a Marra Forni Oven ▶

Our Rotator ovens are available in three different standard sizes: 110cm, 130cm, and 150cm. Ovens are available outside of these dimensions (by custom order) to suit your restaurant's needs. This oven has been extensively tested and approved by the ETL, NSF, and CE.

WARNINGS

Improper installation, adjustment, alteration, service or maintenance can cause property damage, injury or death. Read the installation, operating and maintenance instructions thoroughly before installing or servicing this equipment. Contact your local building or fire officials about restrictions and installation inspection in your area.

- A major cause of oven related fires is failure to maintain required clearances (air spaces) to combustible materials. It is of utmost importance that this oven be installed only in accordance with these instructions.
- Never use this appliance as a space heater to heat or warm the room. Doing so will result in carbon monoxide poisoning and overheating of the oven.
- Never cover any openings in the oven bottom or cover an entire rack with materials such as aluminum foil. Doing so blocks air flow through the oven and may cause carbon monoxide poisoning. Aluminum foil linings may also trap heat and cause a fire hazard.
- Do not store or use gasoline or other flammable vapors or liquids in the vicinity of this or any other appliance. Also, always keep the area under and around this appliance free and clear of any and all combustible materials.
- If using gas as your source of heat, you must post a statement in a prominent location for the event that the user smells gas. This information can be obtained by consulting your local gas supplier.

INSTRUCTIONS TO BE FOLLOWED IN THE EVENT THE USER SMELLS GAS:

1. DON'T TRY TO LIGHT ANY APPLIANCE
2. DON'T TOUCH ANY ELECTRICAL SWITCH- DON'T USE ANY PHONE IN YOUR BUILDING
3. IMMEDIATELY CONTACT LOCAL GAS SUPPLIER. IF YOU CANNOT REACH YOUR GAS SUPPLIER, CONTACT FIRE DEPARTMENT.
4. NEVER USE COMBUSTIBLE MATERIALS OR ADHESIVE TO DECORATE THE FACADE OF YOUR OVEN.
5. CONTACT YOUR LOCAL BUILDING OR FIRE OFFICIALS FOR CLARIFICATION ON ANY RESTRICTIONS ON INSTALLATION OF THIS OVEN IN YOUR AREA, OR NEED FOR INSPECTION OF OVEN INSTALLATION.
6. IT IS RECOMMENDED THAT THIS OVEN BE INSTALLED, MAINTAINED AND SERVICED BY AUTHORIZED PROFESSIONALS.

Please keep this manual for future reference for operating your oven. If you are in need of maintenance and/or repairs, please contact us directly at 1.888.239.0575.



Lifting and Moving Your Oven ▶

IMPORTANT: Only trained professionals using the proper machinery and handling equipment should lift and move the oven. Damage to the appliance, voiding of warranty, and personal injury may occur due to improper handling. Forklift ovens from sides. For Model 90, pick up from center crossbars.

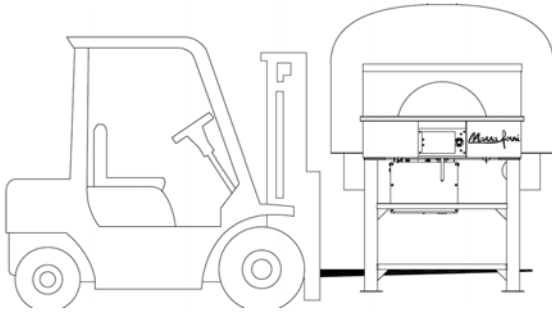

a. Using a Forklift

Before attempting to lift or move the oven, ensure that the forklift capacity can accommodate the weight of the oven, and that the forks are long enough to securely lift the oven with **BOTH** horizontal steel tubes, ensuring that no contact with the oven shell is made. The oven should be approached from either the front or the back to ensure even weight distribution. **BE SURE TO KEEP FORKLIFT STRAIGHT.** Guide forks through the inside of the steel support legs and carefully position underneath the horizontal steel tube members. Proceed to lift and move oven slowly. See picture.

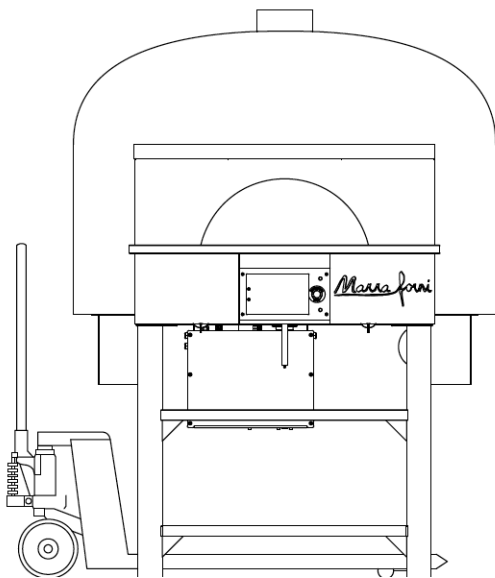

b. Using a Pallet Jack

Ensure that the pallet jack capacity **DOES** accommodate the oven's weight, and that the jack is long enough to securely lift the oven with **BOTH** horizontal bottom steel tubes. The oven should be approached from either the front or back to ensure an even weight distribution. Guide the pallet jack through the inside of the bottom of the steel support legs and carefully position underneath previously mentioned horizontal steel tubes. Proceed to lift slowly and move oven as needed. Use 21" wide pallet jack for the Model 90. For all other models use regular pallet jacks that meet the necessary capacity. See picture.

Important Information/Clearances and Requirements ▶

Clearances combustible/non-combustible construction:

Combustibles:

Sides: 2"

Back: 2"

Non-Combustibles:

Sides: 0"

Back: 0"

Note:

On the bottom half of the oven there must be a minimum opening of 24" x 24" to allow air to enter the burner housing for proper combustion. If this opening is not sized to accommodate proper combustion, it may cause damage to the burner system. Installation of a sealed enclosure around the oven shell may also cause starving of the burner system. The use of return air or other ventilation systems within a sealed enclosure surrounding the oven can also disturb operations. For more information, please call 1.888.239.0575. Never obstruct the flow of combustion and ventilation air to the oven.

Electrical Requirements:

USA

- 120v/single phase/50-60 Hz/12 Amps
- 9ft. power cable integrated
- Use a non-GFI outlet when possible. Otherwise, a dedicated GFI outlet is required.

Europe

- 220v/single phase/50-60 Hz/12 Amps
- 274 cm power cable integrated
- Use a non-GFI outlet when possible. Otherwise, a dedicated GFI outlet is required.

Note:

This appliance must be electrically grounded in accordance with local codes or in the absence of local codes, with the national electrical code ansi/nfpa 70, or with the Canadian electrical code csa c22.1 or European CE ICE 60335-1 as applicable.

Gas Requirements

USA

- Gas connections 3/4" NPT per burner, quick disconnect gas hose must be used.
- 84,000 BTU's per burner.

Europe

- Gas connections 3/4" NPT per burner, quick disconnect gas hose must be used.
- 25 kW per burner.

Note:

Installation must conform with local codes, or with the national fuel gas code ansi z223.1, the natural gas installation code can/cga-b149.1 or European CE BSEN 203-1.

Venting Requirements:

USA/Europe

- The oven is vented through an 8" round duct collar. The Neapolitan wood, gas, and combination gas-wood ovens can be installed with a listed exhaust hood system or with a chimney/grease duct vented outside without an exhaust hood, but must be installed with a power exhausted vent.
- Cubic Feet per Minute: 130CFM
- Static Pressure: 0.007"W.C

Oven Installation instructions ▶

OVENS MUST ONLY BE INSTALLED ON SITE BY AUTHORIZED PROFESSIONALS.

1. Select location for oven to be installed, marking an outline on the floor to ensure that you have adequate space. Floor space must extend to longest points of oven (circumference).

WARNING: INSULATION & OTHER MATERIALS MUST BE KEPT OUT OF THE CLEARANCE SPACES SURROUNDING THE OVEN.

2. Ensure that there is plenty of clearance between the ceiling and your oven. A basic installation with direct venting requires a minimum height of 83 inches from floor to ceiling. All combustible sidewalls projecting beyond the front of the oven opening must be given a clearance of 30" from the side of the oven door opening, and 36" from the front of the oven door, as shown on Figure 1A. For Non-combustible sidewalls the minimum clearance is 0" as shown on Figure 1B.

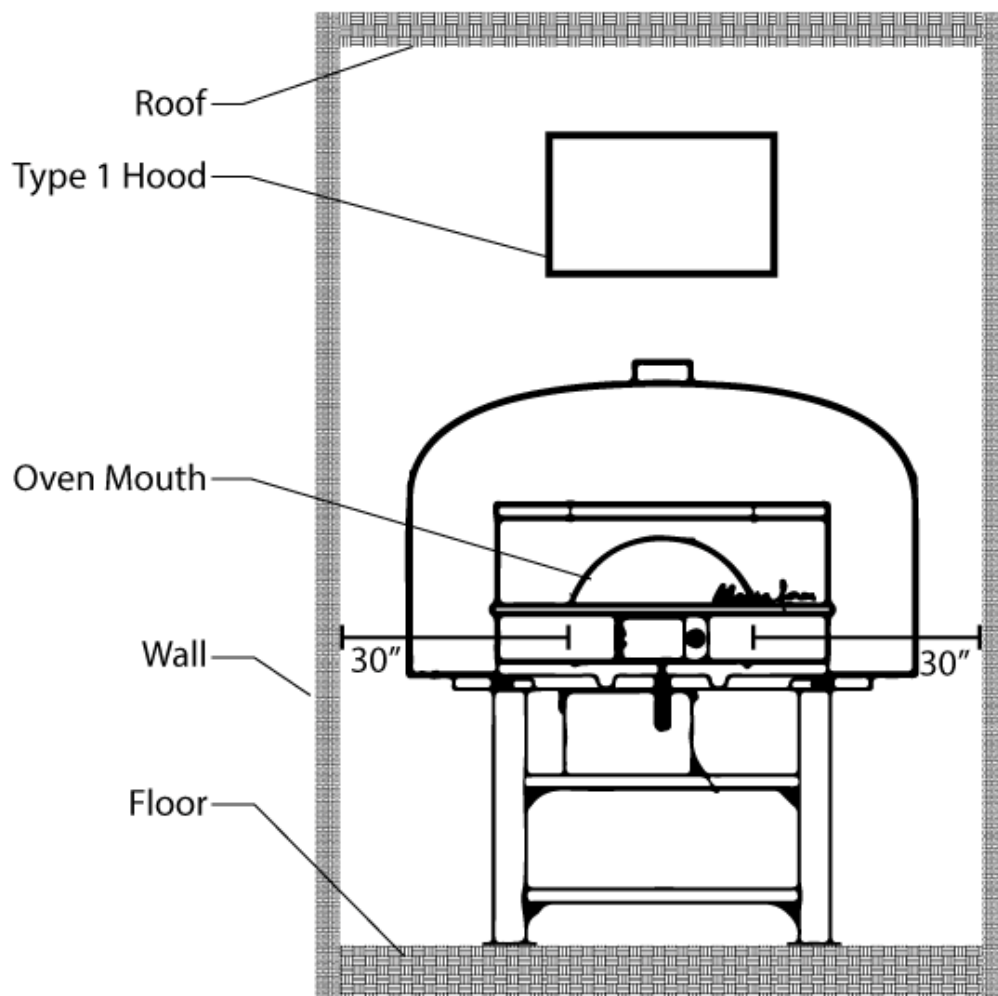

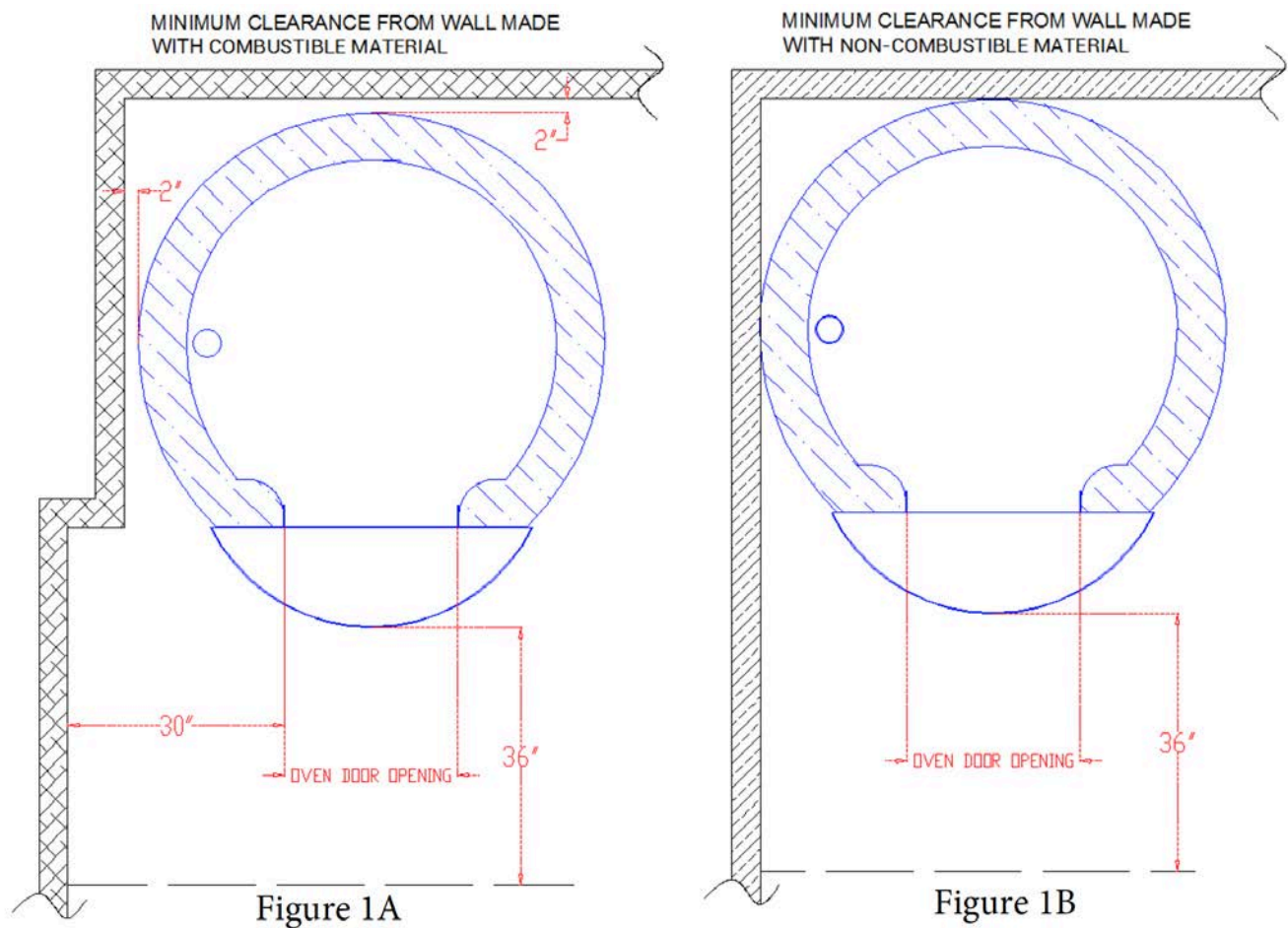

3. OPTIONAL: After completing steps 1-3, oven is recommended to be anchored. Drill holes have been provided at the feet of the oven stand for anchor bolts. Refer to local codes and jurisdiction.

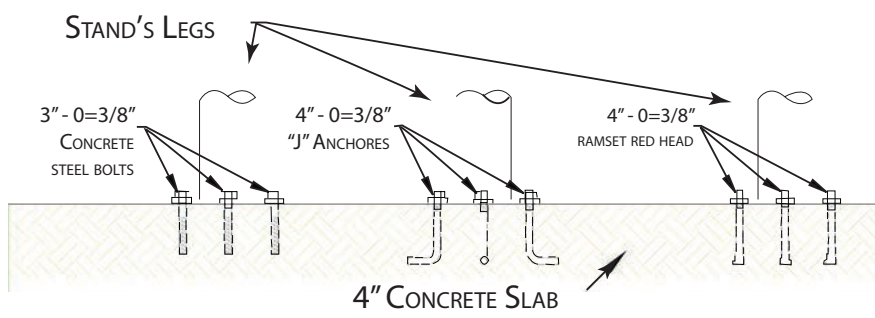

4. Non-combustible materials such as brick, ceramic tile, stainless steel, marble and other decorative metals may be used to face the outside surface of the oven dome if desired. NOTE: NEVER USE COMBUSTIBLE MATERIALS OR ADHESIVE TO DECORATE THE FACADE OF YOUR OVEN.

DIRECT VENTING - TYPICAL ▶

Diameter of inside grease duct by oven size:

.90M (6" duct), 1.10M (8" duct), 1.40M (8" duct), 1.50M (8" duct).

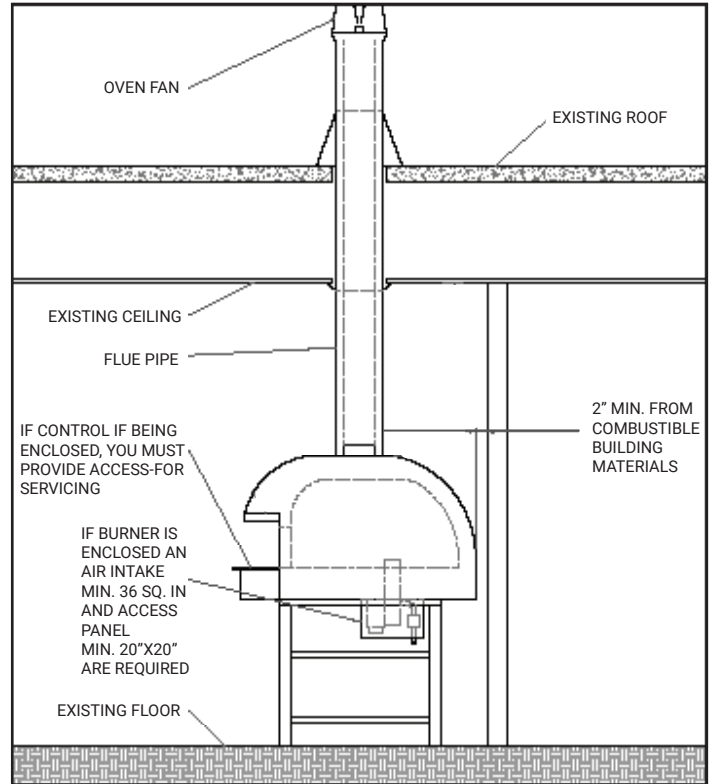
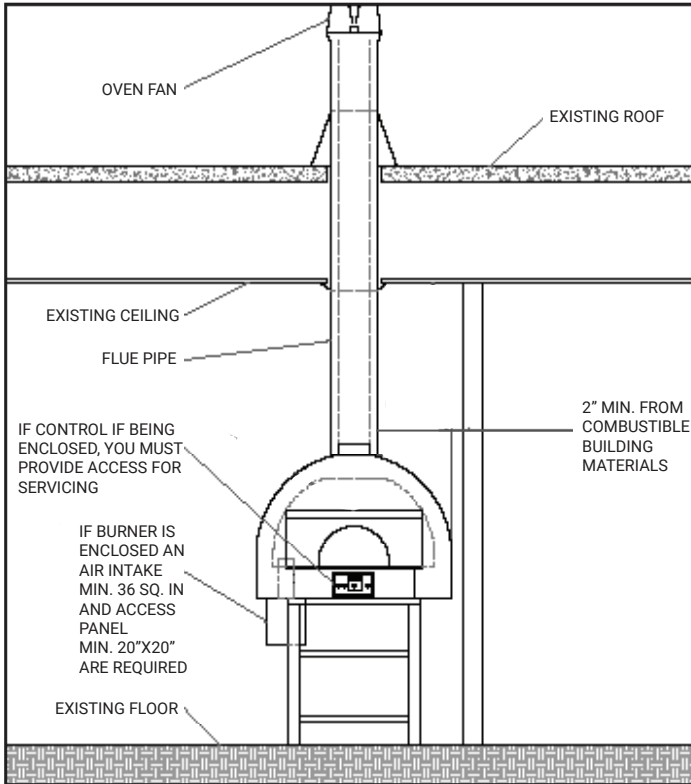

Examples:

The above diagram depicts the installation required for a direct venting application that complies with ETL guidelines. Be sure to contact your local authorities to explore local jurisdiction regarding fire rated duct shafts.

Note: The chimney must be installed in accordance with the manufacturer's grease duct installation instructions. To maintain the ETL listing of the oven, the system must be a UL listed fire-wrapped grease duct in either stainless steel, black iron, or a listed building grease duct.

For Marra Forni venting, refer to the Exhaust System installation Manual. For all other flue systems, consult your manufacturer.

Ventilation Requirements ▶

A UL-listed grease or building heating appliance chimney installation (referred to as direct venting), and Type I exhaust hood installed per NFPA 96 and MC standards for Ventilation Control and Fire Protection of Commercial Cooking Operations are the only two methods of venting permitted for commercial Marra ovens. Of the two options, direct venting is more common, although an exhaust hood is required in some areas (consult local ordinances). Venting must comply.

A UL Listed Grease Duct/Building Chimney Heating Appliance can be connected to the chimney opening of the oven. A listed power ventilator for restaurant exhaust appliances is required. A minimum temperature rating of 500°F is required for the power ventilator.

*Refer to Marra Forni instructions for specific Direct Venting installation requirements. A field-built duct, constructed and installed to NFPA 96 or International Mechanical Code grease duct specifications, may also be used. Volume: 150-200 CFM

Note: The chimney must be installed in accordance

*Type I Exhaust hood standards for ventilation control and fire protection of commercial cooking operations are as follows: Steel baffle (NOT MESH) grease filters must be used and placed at the rear of the hood. The following specifications must also be met:

- There must be at least 10" between the front of the oven face and the front of the hood.
- According to UMC there must be 42" between the oven heart and the face of the filter.
- The side of the hood must extend a minimum of 6" to either side of the oven door opening.

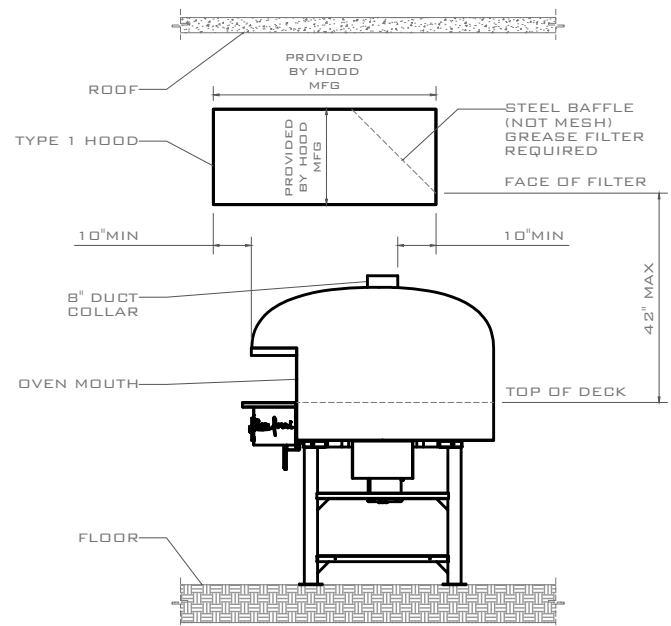
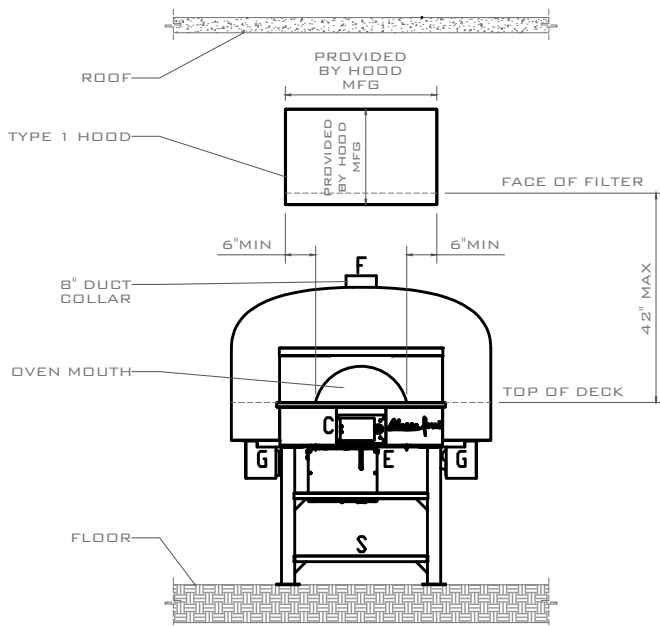

Structural Build of Oven ▶

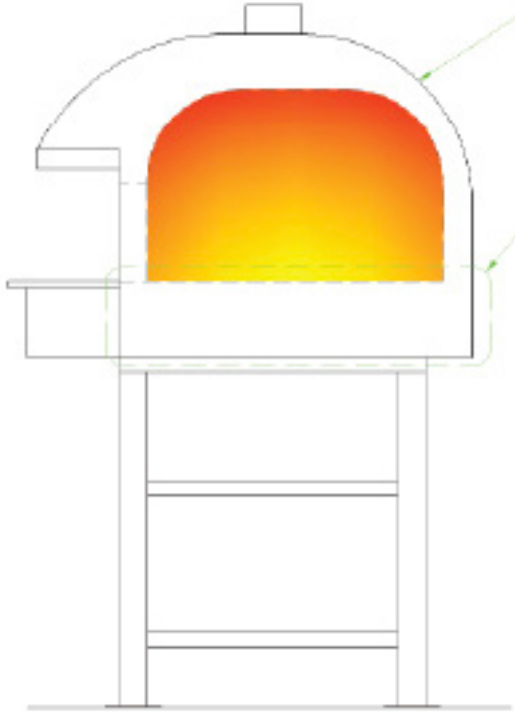

From Inside to Outside:

- 8 cm thick bricks layered over metal mesh
- 3 cm refractory mortar sprayed over mesh
- 4 cm Fyrewrap insulation
- 6 cm Thermafiber mineral wool insulation
- 3 cm refractory mortar
- 6 cm refractory brick
- 1 cm refractory mortar
- 6 cm refractory brick
- 3 cm Thermafiber mineral wool
- 4 cm Fyrewrap insulation
- 2 mm metal

Gas Installation ▶

1. A gas oven should only be connected to the type of gas for which it is equipped.
2. Before operating the oven, please ensure that there are no leaks in any of the pipes or joints by using a soap and water solution. **DO NOT CHECK FOR LEAKS UTILIZING AN OPEN FLAME.**
3. To check the manifold pressure, a 1/8 pressure tap can be found on the combustion gas control. For the proper setting, refer to the nameplate. This control is preset at the factory before shipping.
4. Connect a 3/4" gas supply to oven. On all threaded joints, be sure to use a pipe joint compound that is non-reactive to gas. We recommend that you have a service shutoff valve installed outside of the oven at the time of installation.
5. Connect your gas burner control box to your 120V, 50-60hz, 12 AMP, 1 PH power supply. **ALWAYS BE SURE THAT THE SYSTEM IS PROPERLY GROUNDED.**

Gas Specifications ▶

INSTALLATION MUST CONFORM WITH LOCAL CODES, OR IN THE ABSENCE OF LOCAL CODES, WITH THE NATIONAL FUEL GAS CODE, ANSI Z223.1/NFPA 54, OR THE NATURAL GAS AND PROPANE INSTALLATION CODE, CSA B149.1, AS APPLICABLE, INCLUDING:

1. The appliance and its individual shutoff valve must be disconnected from the gas supply piping system during any pressure testing of that system at test pressures in excess of 1/2 psi (3.5 kPa).
2. The appliance must be isolated from the gas supply piping system by closing its individual manual shutoff valve during any pressure testing of the gas supply piping system at test pressure equal to or less than 1/2 psi (3.5 kPa).
3. The appliance, when installed, must be electrically grounded in accordance with local codes, or in the absence of local codes, with the National Electrical Code, ANSI/NFPA 70, or the Canadian Electrical Code, CSA C22.2, as applicable.

The supply line must be equipped with a manual shutoff valve. This valve should be located in the same room, but external to the range. It should be in a location that allows ease of opening and closing.

!!! DO NOT BLOCK ACCESS TO THE SHUTOFF VALVE.

The vent line from the gas appliance pressure regulator shall be installed to the outdoors in accordance with local codes, or in the absence of local codes, with the National Fuel Gas Code, ANSI Z223.1/NFPA 54, or the Natural Gas and Propane Installation Code, CSA B149.1, as applicable.

!!! DO NOT OBSTRUCT THE FLOW OF

COMBUSTION/VENTILATION AIR.

Rotator Ovens are equipped with a gas connection. Have a licensed gas installer perform the hook-up and test all fittings and pipe connections for leaks. Use approved gas leak detectors (soap solutions or equivalent) over and around the fittings and pipe connections.

!!! DO NOT USE FLAME TO TEST FOR LEAKS!

Guidelines for Oven Use ▶

1. **READ INSTRUCTIONS CAREFULLY.** Improper use of this oven may result in fire and/or personal injury. All operators and supervising personnel **MUST READ AND THOROUGHLY UNDERSTAND THESE INSTRUCTIONS.** This oven is to be operated by trained and qualified personnel only and never left unattended. This oven is a heat-producing appliance and may cause severe burns if the inside is touched.

2. This unit is designed to be used as a gas-fired oven. Only pizza and/or bread products should directly touch the hearth. Please refer to the manufacturer's operation guidelines for instructions on cooking other foods.

3. **DO NOT OVER-FIRE.** If flames spill out from the door opening or the oven temperature exceeds 1000°F, you are over-firing. **DO NOT** fully close the door while a fire is in the oven. This cuts off oxygen, causing the fire to erupt when the door is removed.

4. Keep a gas fire-rated fire extinguisher close to the oven at all times. Ensure that all personnel and supervisors are aware of its location and use, as well as what to do in case of a fire emergency. **DO NOT** use liquid fuels to begin a fire, **DO NOT** use liquids to extinguish a fire.

7. To prevent sparks from entering ductwork, exhaust systems serving Solid Fuel equipment **MUST NOT** be combined with exhaust systems serving other (non-solid fuel) cooking equipment. Consult local authorities for regulations concerning proper exhaust installation.

8. **DO NOT USE PRODUCTS NOT SPECIFIED FOR USE WITH THIS OVEN.**

9. **NEVER BURN OTHER FUELS IN THE OVEN SUCH AS LIQUIDS, CHARCOALS OR GARBAGE.**

10. If installed **WITH** an exhaust hood, provisions

must be made to supply sufficient combustion air into the oven during use. Combustion air must be supplied in accordance with local codes and the Uniform Mechanical Code, as well as NFPA 96. The exhaust hood and make-up air blowers must be on at all times when firing. If the exhaust hood power ventilator fails, close the oven door to extinguish the fire and prevent temperature buildup in the hood duct, which can activate the emergency suppression system. Exhaust hoods must extend a minimum of 12" from the opening of the oven. **NEVER** close the oven door fully unless there is an emergency.

11. Use only non-combustible hearth tools and cooking implements inside the oven (we offer an entire line of Marra Forni pizza making tools).

Note: Small cracks and separation where the metal meets the dome, may appear during the curing process and during normal operation of the oven. This is due to the different rates of expansion and contraction. This will not hinder the performance of the oven in any way.



Operation Instruction ▶

Operation area might be a brightly lit, well ventilated area. If light and ventilation are not substantial, provide for additional appliances.

!!! WARNING

DO NOT OPERATE WITHOUT REMOVABLE MOTOR BOX PANEL.
NEVER OPEN MOTOR BOX.

!!! WARNING

HOT WHILE IN OPERATION.
KEEP CHILDREN, PETS, CLOTHING AND FURNITURE AWAY.
CONTACT MAY CAUSE SKIN BURNS.
DO NOT BURN GARBAGE OR FLAMMABLE FLUIDS.

BEWARE OF VERY HIGH TEMPERATURES IN THE OVEN.
USE LONG OVEN GLOVES AND MITTS TO HANDLE POTS AND TOOLS.
DO NOT PUT UNPROTECTED HANDS OR ARMS INSIDE WHILE OVEN IS LIT.
USE ONLY SHOVELS TO MOVE FOOD INSIDE COOKING SPACE.

Only pizza and bread products may be cooked directly on the oven's cooking plate. Other kinds of food may be cooked in pans or other suitable containers to prevent spillage onto the oven deck.



Emergency Stop ON/OFF Button-Turns oven ON/OFF.

Control Box-Controls oven functions.

Controller Console - Default Screen ▶

Rotator Series



Home Button - Prompts user to Select Mode Screen

Technical Service Button

N/A

Marra Forni Welcome Screen

Controller Console - Language, Time, and Date Setup ▶



English Button-Sets language to English



Spanish Button-Sets language to Spanish



Italian Button-Sets language to Italian



French Button-Sets language to French



German Button-Sets language to German

12:00 AM 01-01-97 Time/Date Button-Sets Time/Date

Intro to Curing ▶

Curing is necessary to ensure that your oven is free of moisture. The interior of the oven will appear dry upon arrival, but there is still a small amount of moisture in the bricks and mortar. If you neglect to cure your oven, the oven will become damaged during use. If you do not have your oven delivered pre-cured, you **MUST** follow these steps. The curing process takes a total of 5 days to complete.

IMPORTANT: NEVER burn liquid fuel, or any treated, coated, or laminated woods.

Note: Curing will automatically start on Day 1. If you choose to cure manually, set the temperature each day, then press Turn on Burners.

GAS OVEN CURING SCHEDULE

- Day 1: Burn at 300°F for 3 hours.
- Day 2: Repeat process at 400°F.
- Day 3: Repeat process at 500°F.
- Day 4: Repeat process at 600°F.
- Day 5: Repeat process at 700°F

Do not speed up curing Process. Follow exact instructions above. Do not shut off or unplug the oven. The oven will turn on by itself every day and it will complete the 5 day cycle. If the oven is turned off or unplugged you will have to cure manually.

Oven temperature will increase above set temperature. Oven is not built for low temperature. Temperature increase is normal.

Controller Console - Start Curing Process ▶

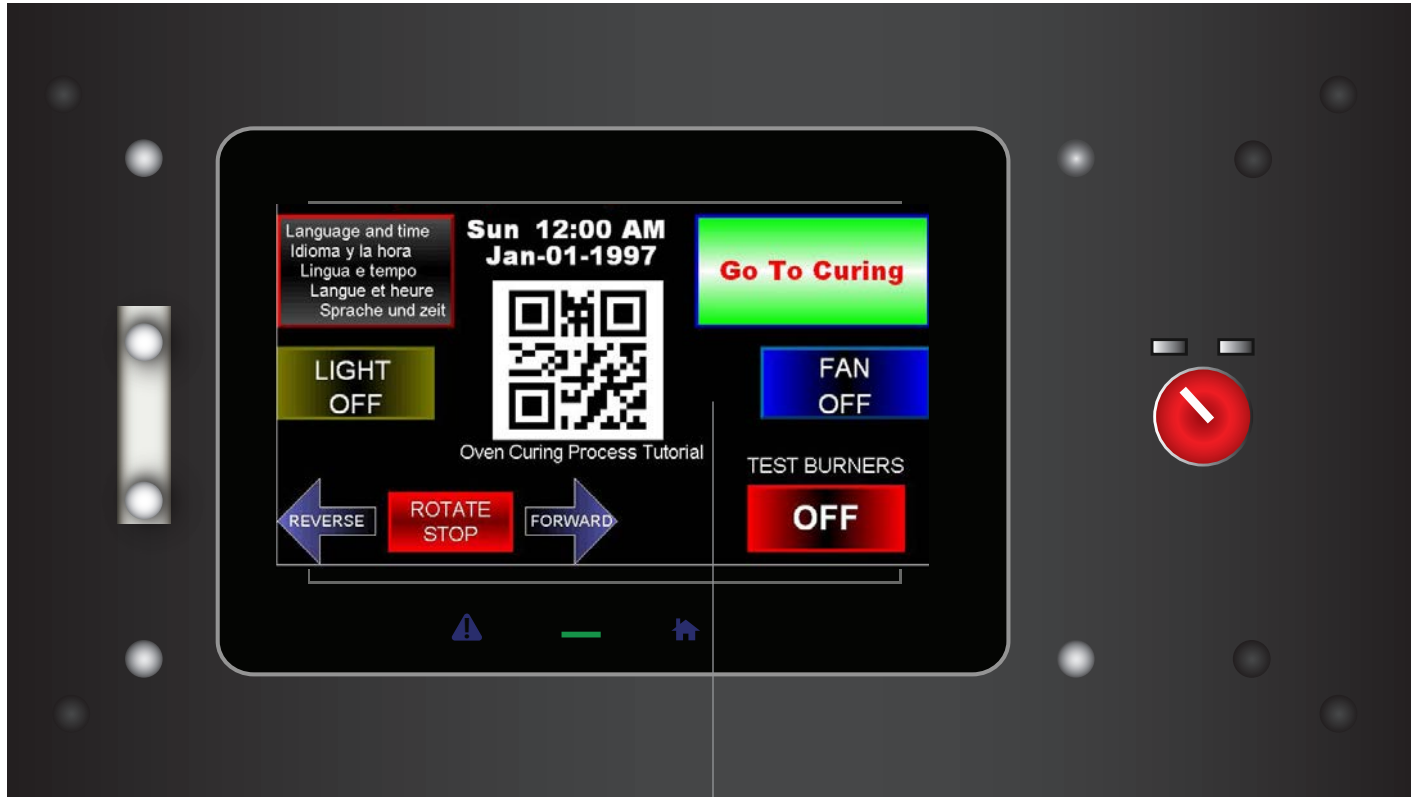

Start Curing Process Button - Press Start Curing Process to commence the 5-day curing process.

Curing is necessary to ensure that your oven is free of moisture. The interior of the oven will appear dry upon arrival, but there is still a small amount of moisture in the bricks and mortar. If you neglect to cure your oven, the oven will become damaged during use. If you do not have your oven delivered pre-cured, you **MUST** follow the following steps. The curing process takes a total of 5 days to complete.

IMPORTANT: NEVER burn liquid fuel, or any treated, coated, or laminated woods. The **ONLY** acceptable type of wood to use is dry, medium, or hard firewood.

Controller Console - Confirm Curing ▶

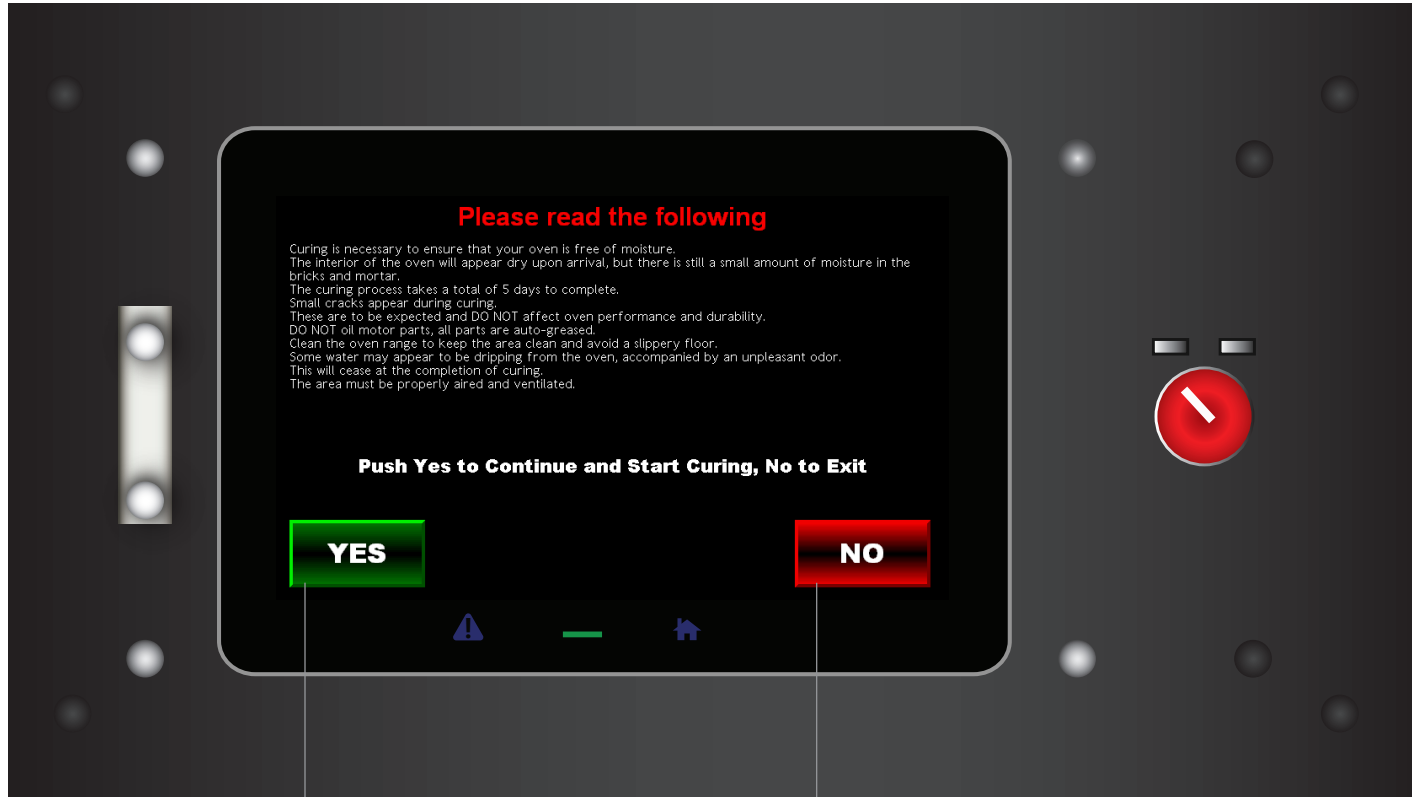

Yes Button-Confirms
and initiates curing process.

No Button-Aborts curing process

Controller Console - Curing:Day 1-5 ▶

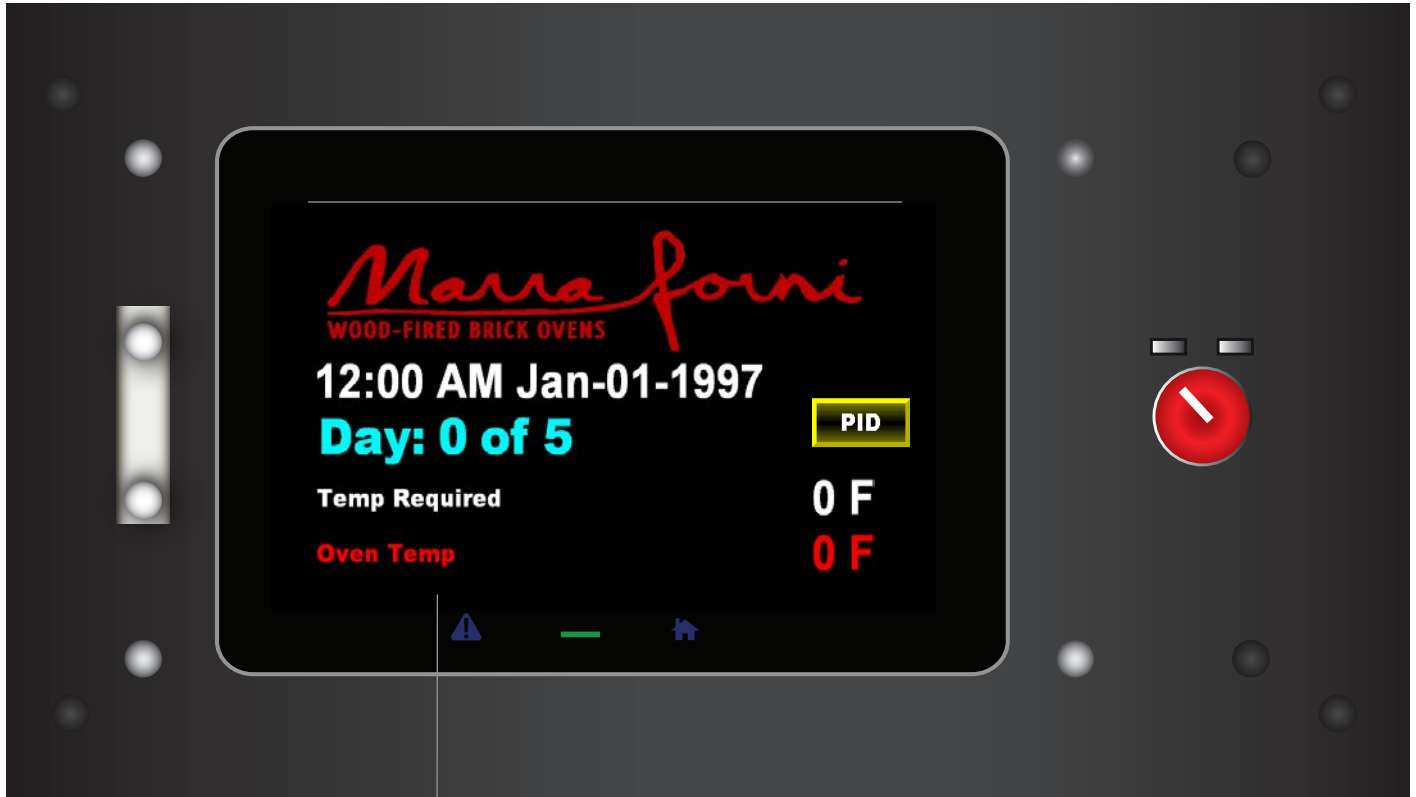

Day 1 thru 5-Curing screen. The oven will automatically and set temperature for five day curing process.

Small cracks appear during curing. These are to be expected and DO NOT affect oven performance and durability.

Clean the oven range to keep the area clean and avoid a slippery floor.

Some water may appear to be dripping from the oven, accompanied by an unpleasant odor. This will cease at the completion of curing. Clean the oven range to keep the area clean and avoid a slippery floor. The area must be properly aired and ventilated.

**Note: The curing process will continue for 5 days/3 hours each day.
Do not turn off the oven.
Do not turn off the gas.**

Controller Console - Select Mode ▶



Default Recipe Button-
This button directs you to
default recipes provided
by Marra Forni.

User Recipe Button-Directs
user to page where the user
customizes recipes.

Manual Mode Button-
Directs user to manual
mode.

Settings Button-Directs user to
update language, time, and date.

Controller Console - Select Mode: Default Recipe ▶

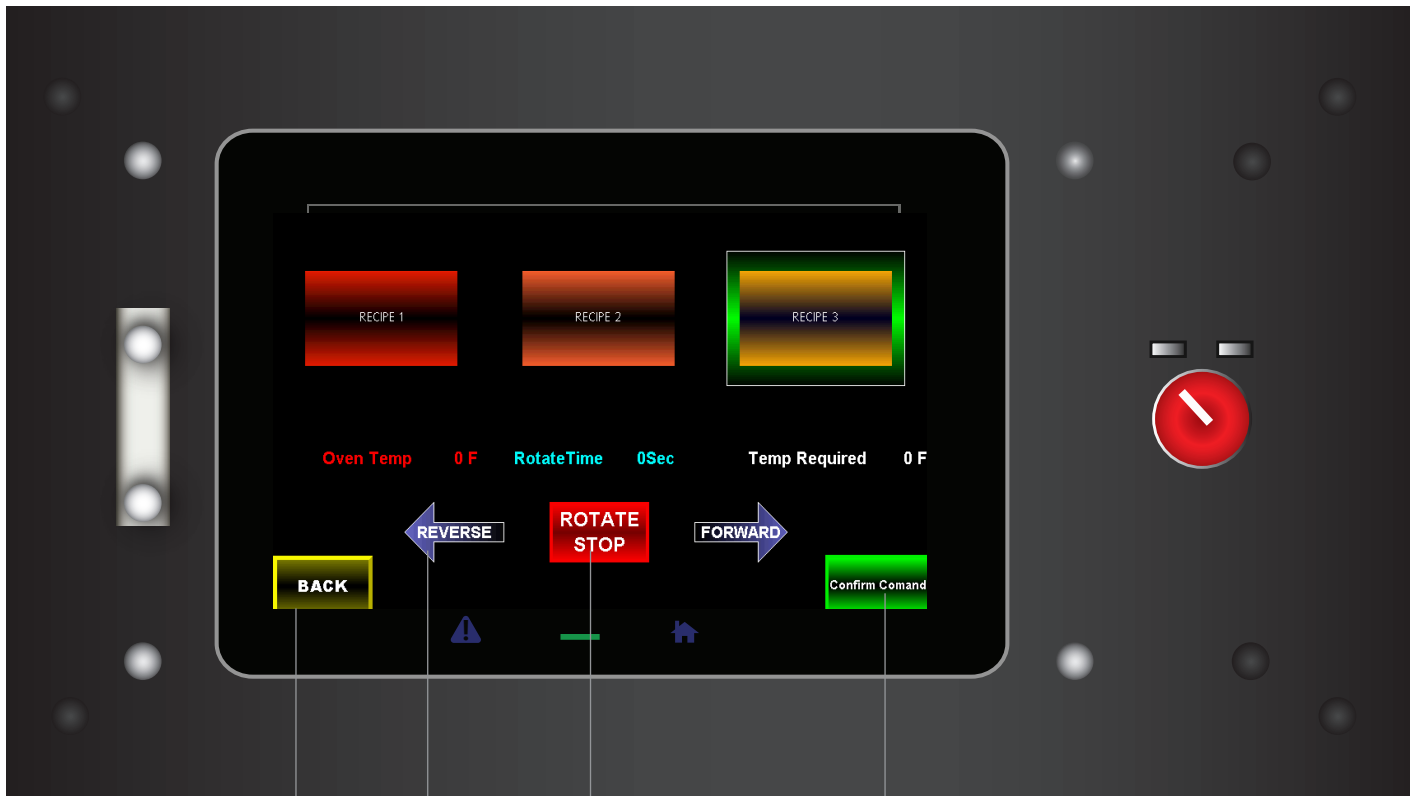

Confirm Command Button-Confirms recipe chosen.

Rotate Stop Button-Brings cooking deck to a complete stop.

Reverse/Forward Button-Changes direction of deck rotation.

Confirm Command Button-Confirms recipe chosen.



Recipe 1 Button-Recipe 1 includes preset temp and rotate time.



Recipe 2 Button-Recipe 2 includes preset temp and rotate time.



Recipe 3 Button-Recipe 3 includes preset temp and rotate time.

Controller Console - User Recipe ▶

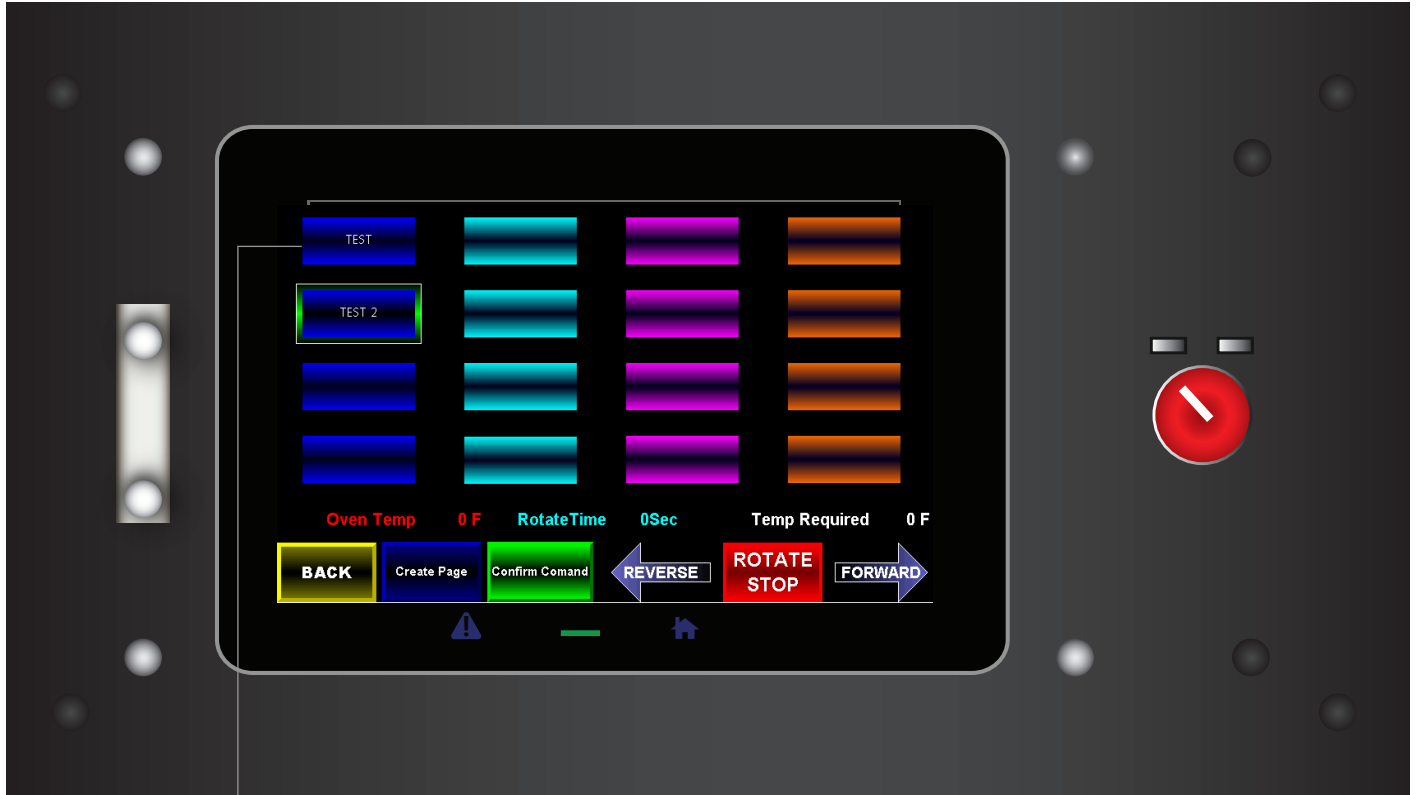

Blank Recipe Button-Recipe to be created.

Create Recipe Button-Creates a new customized recipe and prompts user to recipe setup screen.

Controller Console - User Recipe ▶

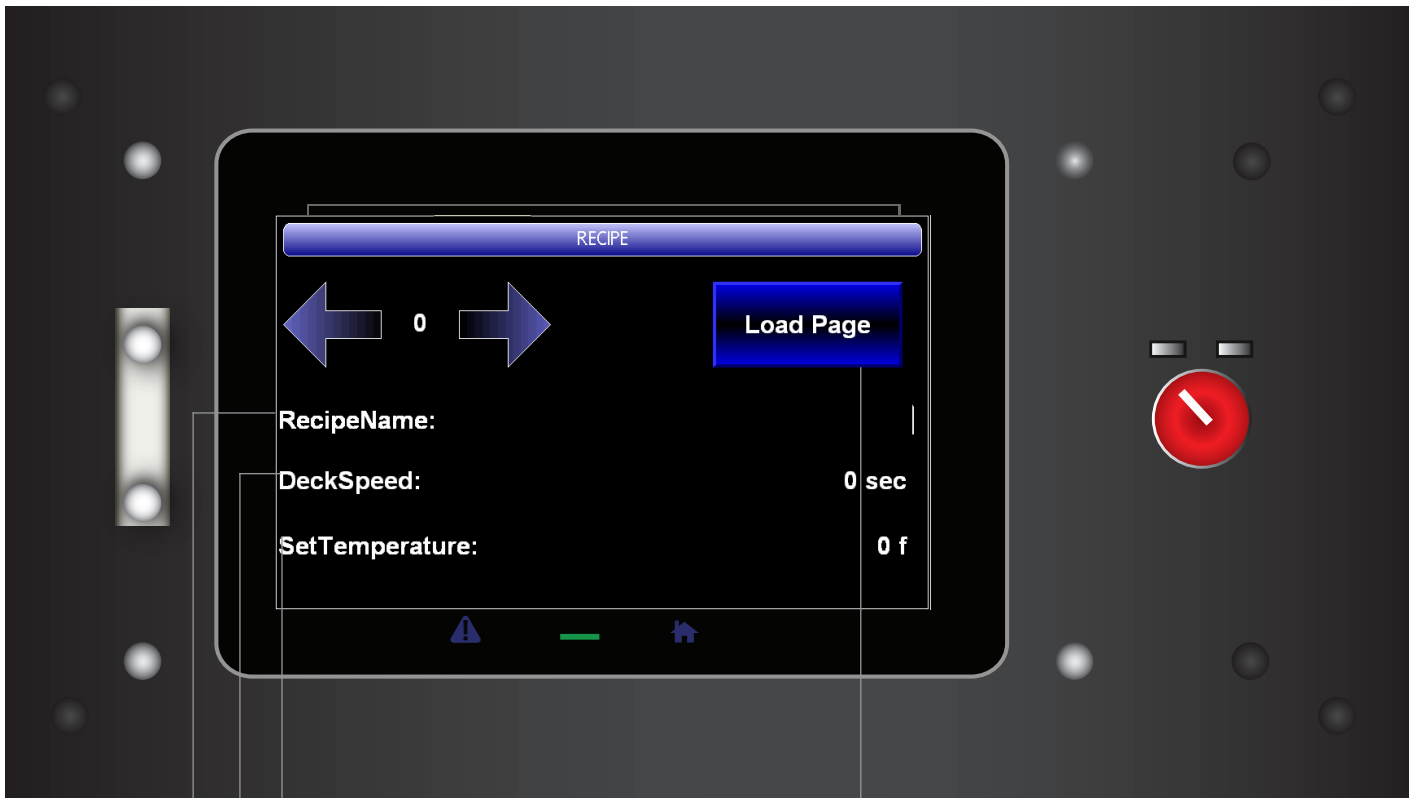

Load Page Button-Loads new recipe to user recipe menu.

Set Temperature Button-Allows user to set temperature for new recipe.

Deck Speen Button-Allows user to set deck speed for new recipe.

Recipe Name Button-Creates customized recipe name.

Customized Recipe complete. Once recipe is created, recipe will automatically be added to your recipe menu. User has the capability of creating sixteen customized recipes.

Controller Console - User Recipe ▶

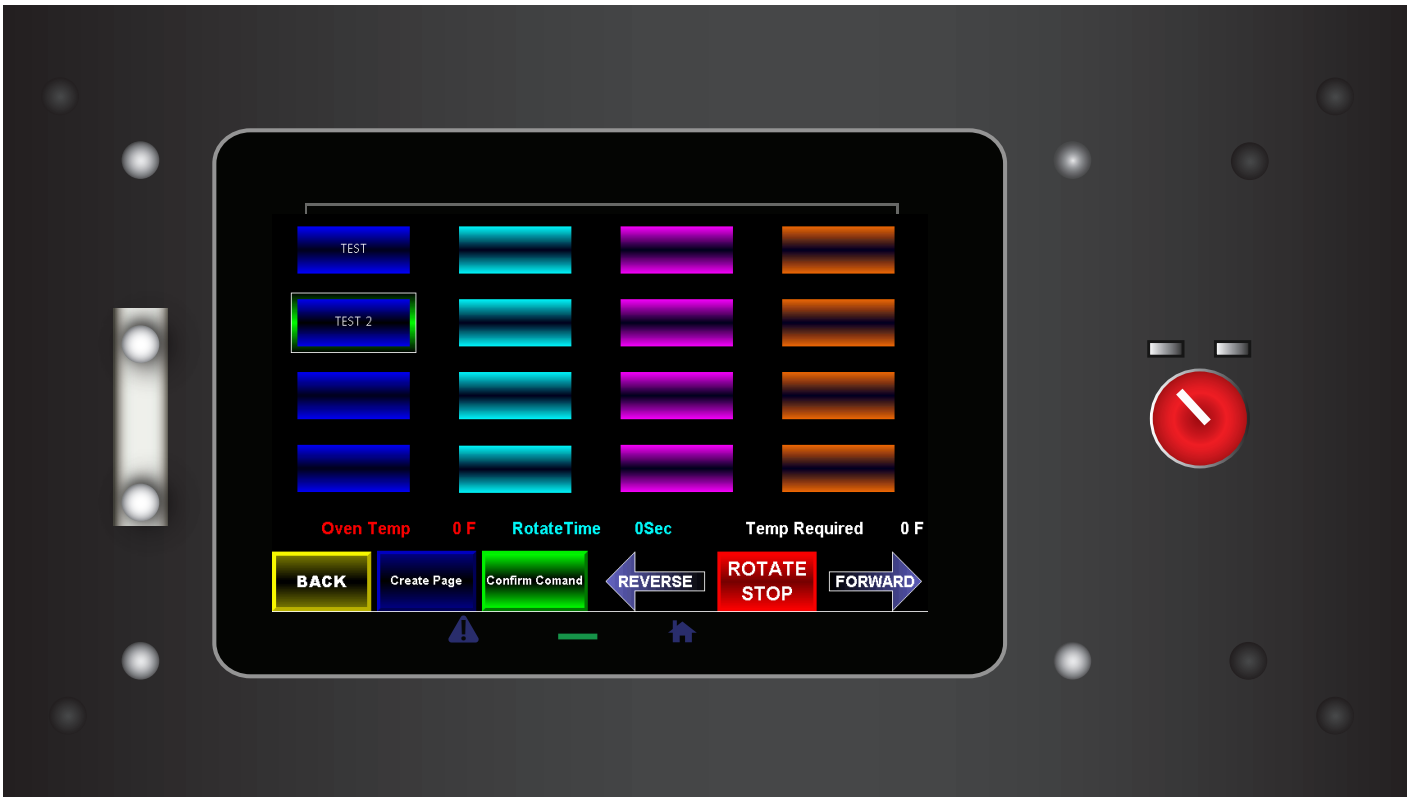

Customized Recipe complete. Once recipe is created, recipe will automatically be added to your recipe menu. User has the capability of creating sixteen customized recipes.

Controller Console - Manual Mode ▶

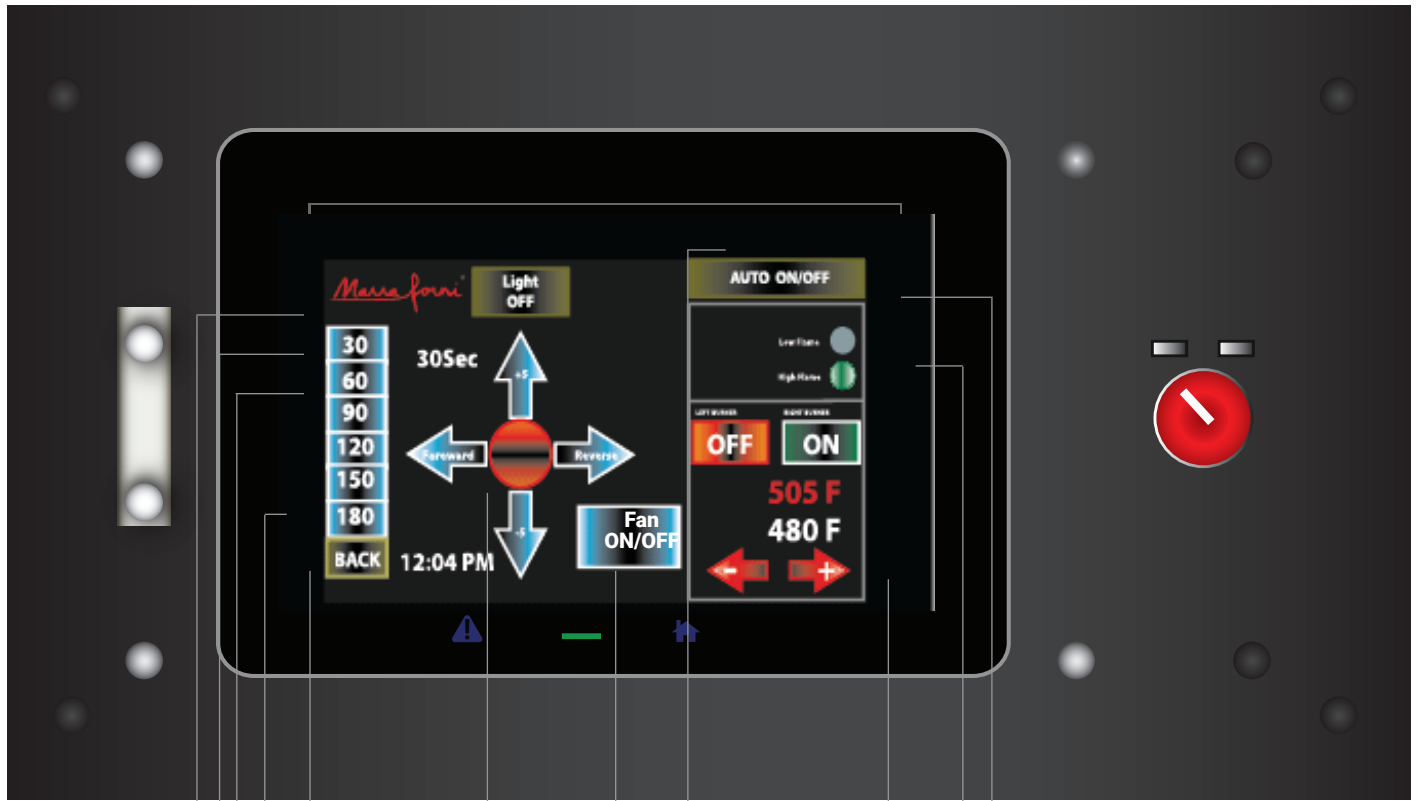

High/Low Flame Indicator-Indicates if burners are on Hgh/Low flame plete stop.

Burner ON/OFF-Button for left and right burner,turns burners ON/OFF.

Temperature Button-Increases and decreases oven temperature.

Fan ON/OFF

Auto ON/OFF Button-Automatically turns oven on or off.
Reverse/Forward and RPM Button-Reverse/Forward button changes direction of deck rotation. RPM button increases or decreases deck speed.

Back Button-Prompts user to previous screen.

180 RPM-Sets cooking deck rotation to 1 rotation per 180 seconds.

90 RPM-Sets cooking deck rotation to 1 rotation per 90 seconds.

60 RPM-Sets cooking deck rotation to 1 rotation per 60 seconds.

30 RPM-Sets cooking deck rotation to 1 rotation per 30 seconds.

Specifications ▶

Model Number	Minimum Firing Rating*	Maximum Firing Rating*	Gas Connection Pipe Size	Gas Pressure Required Natural or Propane	Diameter of Nozzle	Maximum Nozzle Insertion Depth	Motor HP	Design Certification	Primary Safety	Shipping Weight
MFB200	70,000*	200,000*	3/4" NPT	6.0" to 14.0"	4.0"	6.0"	1/22	U.L./C.U.L. Listed	24V	25 lb
MFB300	90,000*	300,000*	3/4" NPT	6.0" to 14.0" W.C.	4.0"	6.0"	1/12 U	.L./C.U.L. Listed	24V	25 lb

* BTU/HR

Flame Safety: Direct Spark Ignition with 100% shut-off, 30 second pre-purge, 3 Function Redundant 1/2"NPT Main Automatic Gas Valve

Electrical Supply:
120/1/60, 3 AMP (Standard)
230 Volt 50/60HZ (Available - Contact Factory)

The MFB Series is provided as a fully assembled power burner with an integrated burner control system.

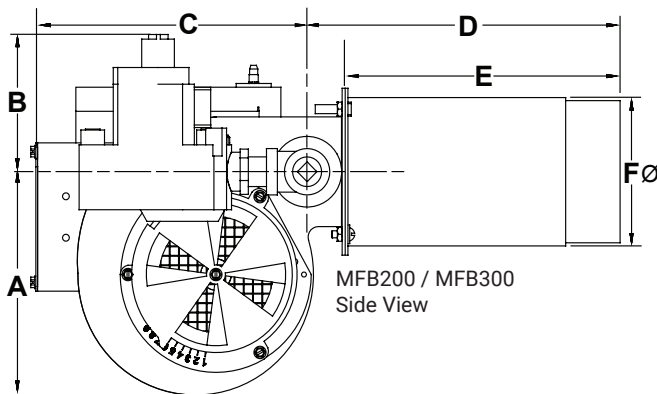

MFB200 / MFB300
Side View

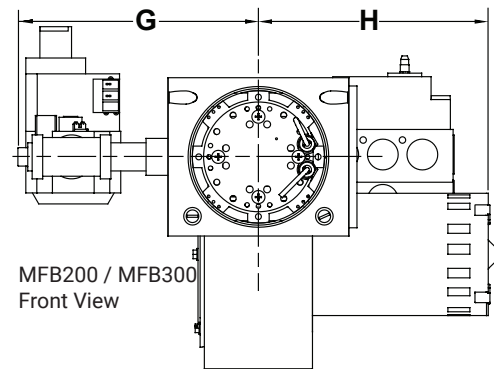

MFB200 / MFB300
Front View

	A	B	C	D	E	F	G**	H
MFB200	5-5/16"	3-11/16"	8"	8-5/8"	7-1/2"	4" Ø	6-13/16"	6-13/16"
MFB300	6-9/16"	3-11/16"	8-3/4"	8-5/8"	7-1/2"	4" Ø	6-13/16"	9"

** Approximate

Electrical Specifications ▶

Voltage 120V/ Single Phase

Frequency 50 - 60Hz

Amp 12

The Rotator oven is configured for connection to a 120V circuit. Always refer to the equipment data plate beneath the oven to verify the proper voltage.

!!! DO NOT CONNECT THIS OVEN RATED 120V TO A DIFFERENT VOLTAGE CIRCUIT. CONSULT A LICENSED ELECTRICIAN TO CONNECT THE OVEN TO YOUR APPROPRIATE CIRCUIT.

Electrical Specifications ▶

Electrical diagrams are located behind control panel and inside motor box, under the oven.

-BURNER DIAGRAM

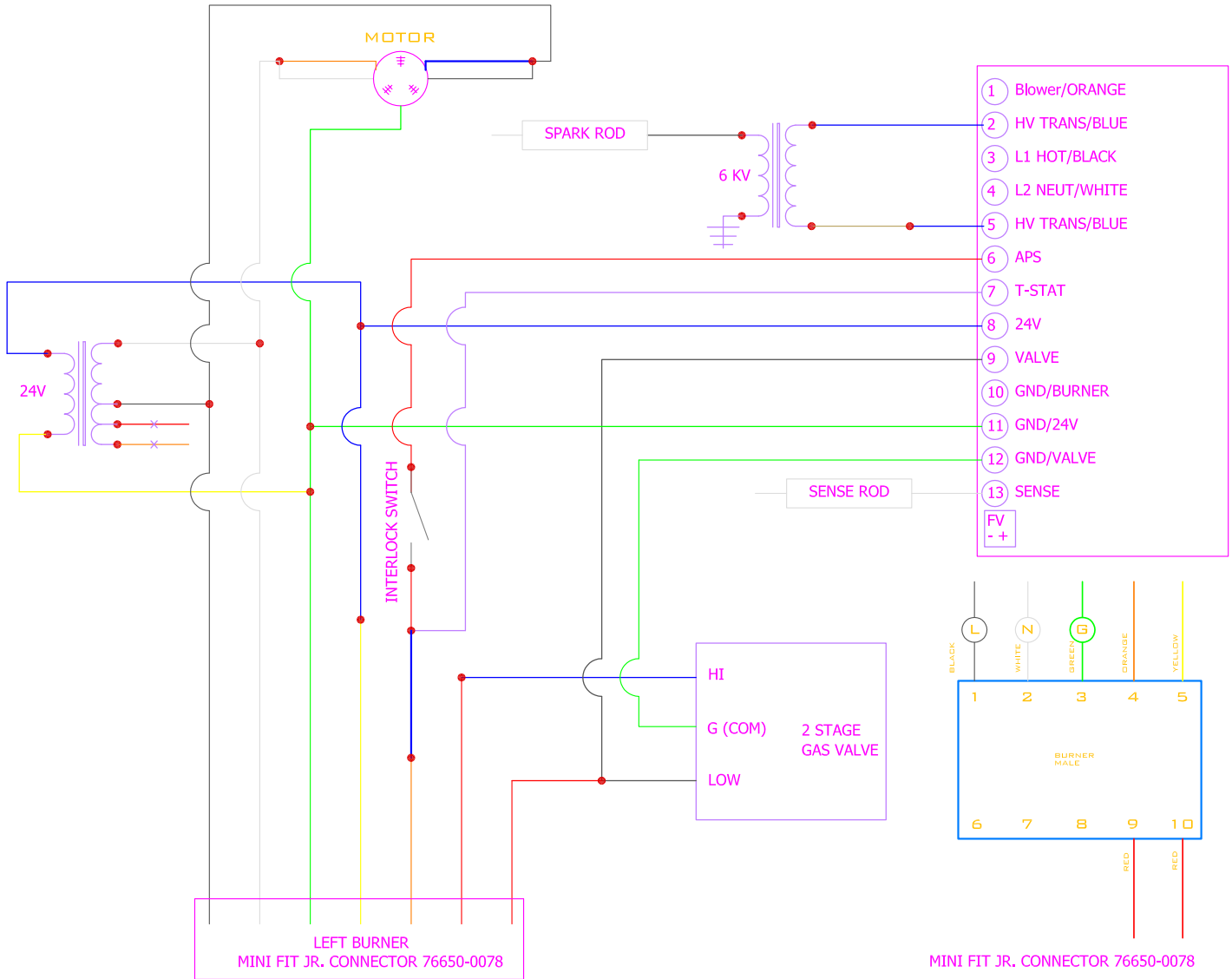

!!! WARNING - ELECTRICAL GROUNDING INSTRUCTIONS

This appliance must be electrically grounded in accordance with local codes, or in the absence of local codes, with the National Electrical code, ANSI/NFPA 70, or the Canadian Electrical code, CSA C22.1 as applicable

DO NOT OPEN OVEN CONSOLE OR GAS CONSOLE.

IF THE OVEN IS NOT OPERATING PROPERLY CALL FOR SERVICE.

Electrical Specifications ▶

-MOTOR BOX

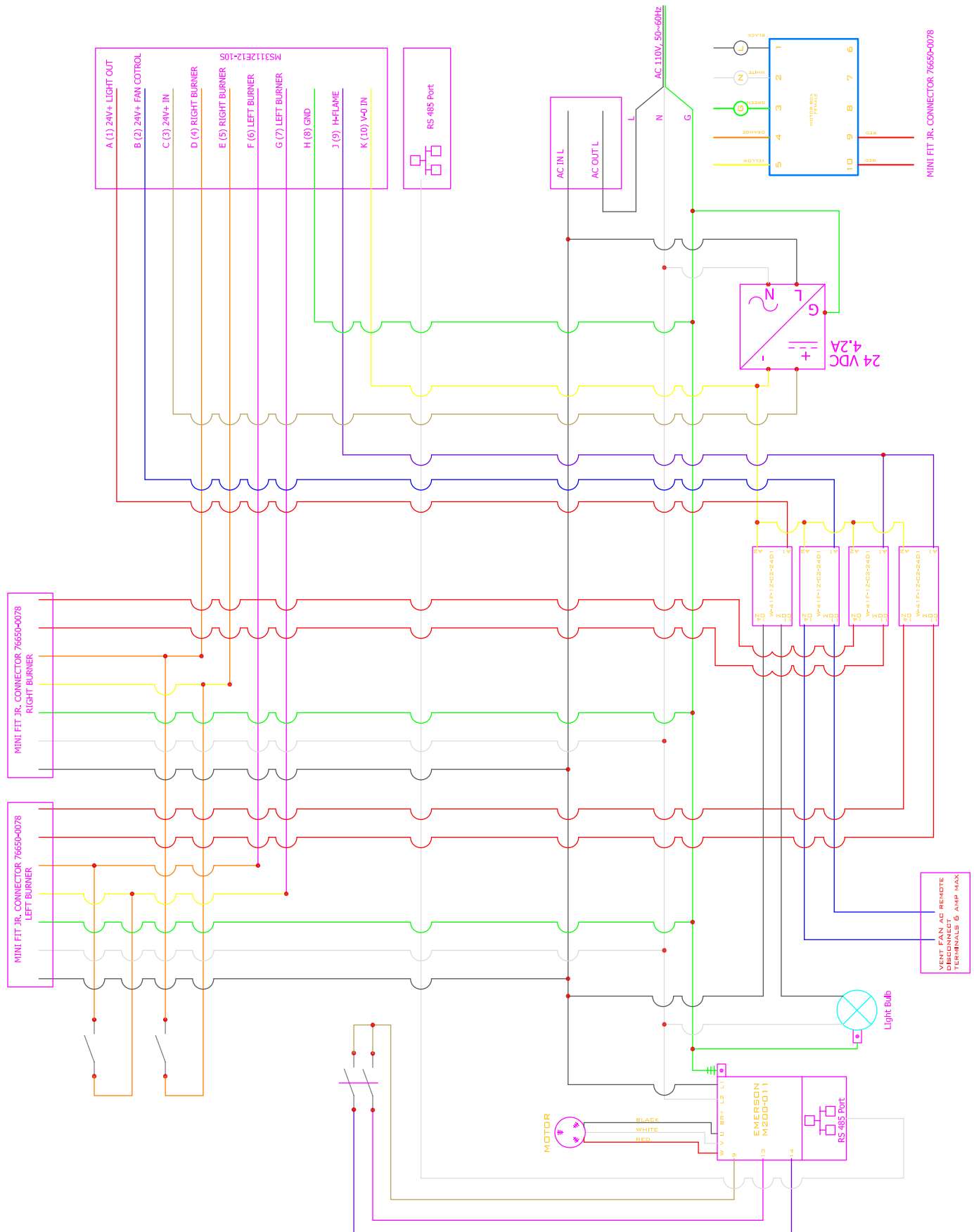

Electrical Specifications ▶

-ROTATE CONTROL

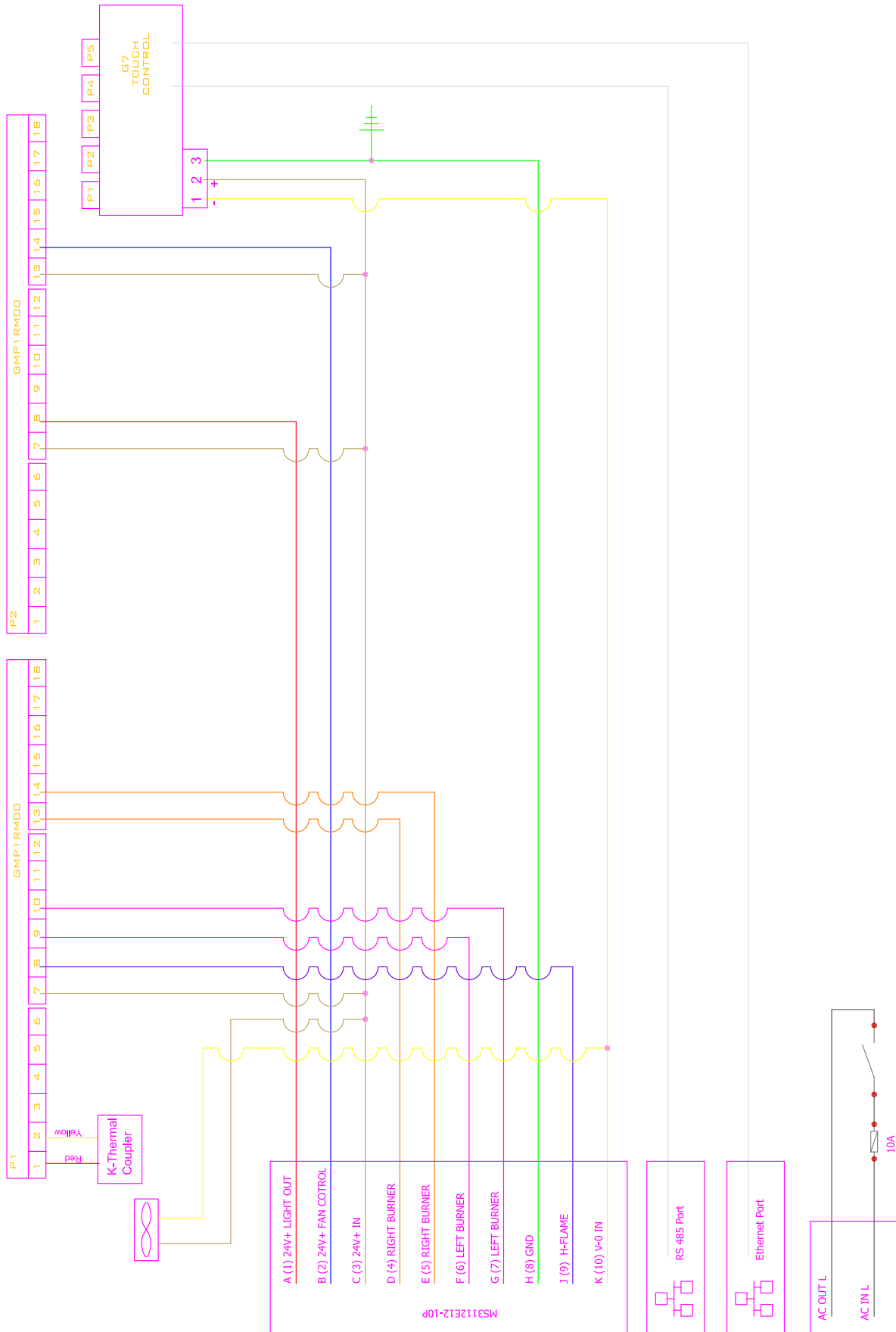

Daily Oven Operations ▶

-OVEN STARTUP

Remove oven door. The door is used for nighttime heat retention. NEVER use the oven when the door is in place. Press the ON/OFF button to start. Set the desired flame amount to achieve your preferred cook temperature.

-OVEN TURN-OFF

Press the ON/OFF buttons to turn the oven off. Wait 5 minutes before relighting the oven. Replace oven door, leaving a gap for heat to escape.

DO NOT POUR OR SPRAY LIQUIDS ONTO THE OVEN DECK OR ONTO THE OVEN INTERIOR AS THIS WILL DAMAGE THE OVEN AND VOID THE WARRANTY.

We recommend keeping a daily or weekly register with preferred temperatures, baking times, etc., as well as any anomalies, operations and all useful information.

Cleaning of Oven Exterior

-FIRE AND PIZZA DOORS

Fire and pizza doors: clean door panels when inside temperature is maximum 50° C (120F), using only a non-inflammable detergent.

-MOTOR BOX

Do not use excessive quantities of liquid when wiping on or around motor box. Some oil may drop: There is no need to adjust, the dropped quantity is a normal oil quantity in excess.

Maintenance and Repairs

FOR NO REASON SHOULD THE BOX MOTOR AND/OR CONTROLLER CONSOLES BE OPENED. MARRA FORNI AND ITS REPRESENTATIVES ARE NOT RESPONSIBLE FOR DAMAGES CAUSED BY NON-AUTHORIZED OPERATIONS.

In case of breakage or malfunction, contact the Marra Forni Representative to perform maintenance and repairs.

WARRANTY

Please see the warranty certificate to know all conditions.

Warranty does not cover oven parts deterioration or damages caused by abnormal oven usage and/or improper care.

Tech Support

techsupport@marraforni.com | 888.239.0575 ext. 131

[Click here](#) to view Marra Forni's technical tutorials.

Burner Cleanout Instructions ▶

THIS PROCEDURE SHOULD NOT TAKE MORE THAN 1 HOUR

1. Turn off the Oven by unplugging the appliance
2. Turn off Main Gas Supply
3. Disconnect Burner Cable from Control Cable (See Picture #1)
4. Disconnect Burner from Gas Hard Pipe or Flex Hose/Quick Disconnect
5. Unscrew Nuts from Circular Flange that attach to bottom of the Base (See Picture #2)
6. Bring down Burner
7. Remove any/all remaining debris from Burner Chamber (See Picture #3)
8. Clean Sensor Rod, Ignition Rod, and Plate with Scotch Brite Pad (See Picture #3)
9. RE-connect Burner Cable to Control Cable (See Picture #1)
10. Only turn on Burner that you are working on for the testing outside the oven
(DO NOT CONNECT THE GAS AT THIS POINT)
11. If there is an arc you are good to go (See Picture #4)
12. Disconnect Burner Cable from Control Cable (See Picture #1)
13. Mount Burner from the Circular Flange to the bottom of the Base with the Nuts (See Picture #2)
14. Connect Burner to Gas Hard Pipe or Flex Hose/Quick Disconnect
15. Connect Burner Cable to Control Cable (See Picture #1)
16. Turn on Gas
17. Plug the appliance
18. Turn on Oven
19. Turn on the Burner
20. Verify Burner is modulating between High Flame and Low Flame



Picture #1



Picture #2



Picture #4

Troubleshooting ▶

Problem	Solution
1. The flame is blue.	1. Check to make sure that the shutter is to 2.5. The shutter should remain set at 2.5 at all times. See Figure One.
2. The flame is stuck on "High" or "Low" setting.	2. Make sure the blue & black wires are connected to the gas valve. After you are sure that all wires are properly connected, test the temperature control dial.
3. The burner shuts itself off.	3. Check the low flame. See Figure 2 for details on how to do this. You may need to adjust the low flame regulator.
4. The burner will not light, and there is no flame in the oven.	4. Is the gas in the oven turned on? Turn the oven off, and then on again to reset. Make sure that the combination gas valve is turned ON.
5. The control box will not turn on.	5. This means that no power is connected to the oven. Check for blown fuses on the back of the control box. If the control box still does not turn on, please contact a Marra Forni representative.
6. The display reads "Open."	6. Make sure that the Thermocouple is plugged into the control box.
7. Flame is set too high or too low.	7. Adjust the high and low flame regulators.
8. The spark igniter does not work.	8. Light the end of a piece of paper on fire and hold over the burner to light the oven. Use this process to light the oven until you are able to call Marra Forni and be issued a replacement burner.

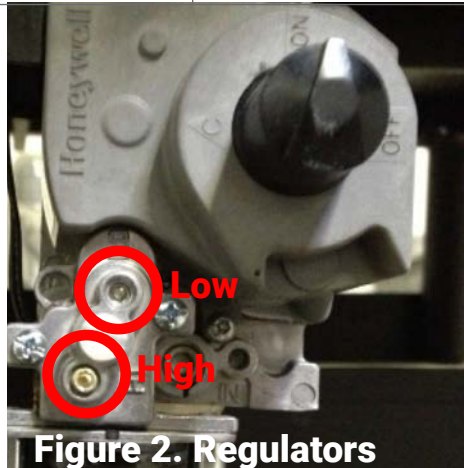
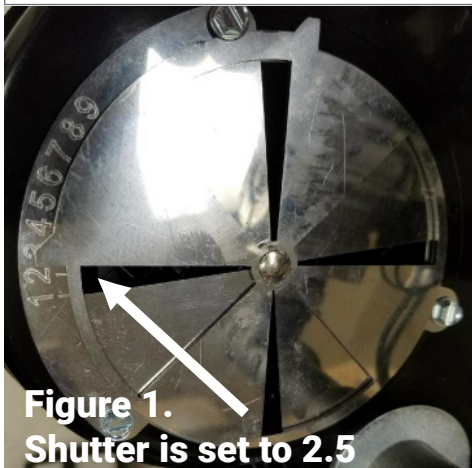

TROUBLE CHART AND RECOMMENDATIONS ▶

TESTING THE GAS SUPPLY SYSTEM

Make sure prior turning the oven on, that the gas supply pressure is above or equal to 0.35 Psi (10 WC) and do not exceed 0.5 Psi (14 WC),

NOTE: ELECTRICAL AND FLAME CHECKS MUST BE MADE IN ORDER LISTED.

1. Check status of electronic burner control diagnostic indicator LED, (refer to IGNITION CONTROL TROUBLESHOOTING FLOWCHART)
2. Confirm that both main manual shut off valve and manual gas cock knob on combination gas valve is in the ON position. Make sure that the thermostat, operating controls and safety controls are calling for heat. Defective wiring or loose connections can simulate malfunctioning components: or any of the conditions below. Check associated wiring and connectors before replacing a component. Whenever the burner fails to light during the seven second trial for ignition, or if the flame is lost during the burner run cycle and not re-established within 37 seconds (30 second pre-purge), the electronic burner control will shut OFF the combination gas valve and lockout the burner. To reset, the burner turn OFF the main knob (switch) on the front of the control, wait 10 seconds and turn knob (switch) ON. Navigate to MANUAL MODE and turn the burner ON. Note; (Have the Set Point 20 degrees above the oven temperature. If the oven temperature is 30 degrees above the Set Point the burner will not turn ON) Not recommended for ground-fault circuit-interrupter (GFCI) 125-volt, single-phase, 15- and 20-ampere receptacle. Electronic burner ignition systems are prone to nuisance tripping and possible ignition failure.
3. Confirm that Oven is properly grounded. (Appliances equipped with a flexible electric supply cord are provided with a three prong grounding plug. It is imperative that this plug be connected into a properly grounded three prong receptacle (recommended dedicated ground). If the receptacle is not the proper grounding type, contact an electrician. Do not remove the grounding prong from this plug)
4. Verify L1 and L2 are not reversed. L1 and L2 are not reversed.
5. Verify there is no voltage present between L2 (White wire) and Ground (Green wire)
6. Blower motor should now be ON. If ON, proceed to step 7. If not ON: Confirm that L1 HOT power is present at BLOWER (ORANGE) wires at the electronic burner control
7. After 30 second blower motor pre-purge, confirm 24V power at GND (24V) terminal on electronic burner control and Ground. If power is not present, replace electronic burner control. NOTE: After the 30 seconds pre-purge period, the controller will simultaneously energize the gas valve and send power to the spark rod, causing an ignition spark at the end of the rod. CAUTION: **Spark generating circuit is HIGH VOLTAGE!** If an ignition spark is not present at the tip of the spark rod, turn the power supply OFF. Inspect Burner surface for debris and carbon buildup: (If debris and carbon buildup are detected on the burner surface, clean Flame Rod Assembly and Spark Rod Assembly). Inspect ignition wire/connectors, spark rod, spark rod positioning, spark rod gap and spark rod ceramic insulator. Adjust, repair or replace as necessary. If an ignition spark is still not present, perform a spark test on the electronic burner control per the electronic burner control manufacturers' recommendations. If spark test fails, replace electronic burner control.
8. Once ignition spark is present, main flame should be present. If not present. Confirm that there is no air in gas line. If so, purge air from gas line. Confirm that 24V power is being delivered to the gas valve (GND (24V) and VALVE on electronic burner control)
9. Check for adequate flame current signal strength with an electrical meter.

IGNITION CONTROL TROUBLESHOOTING FLOWCHART ▶

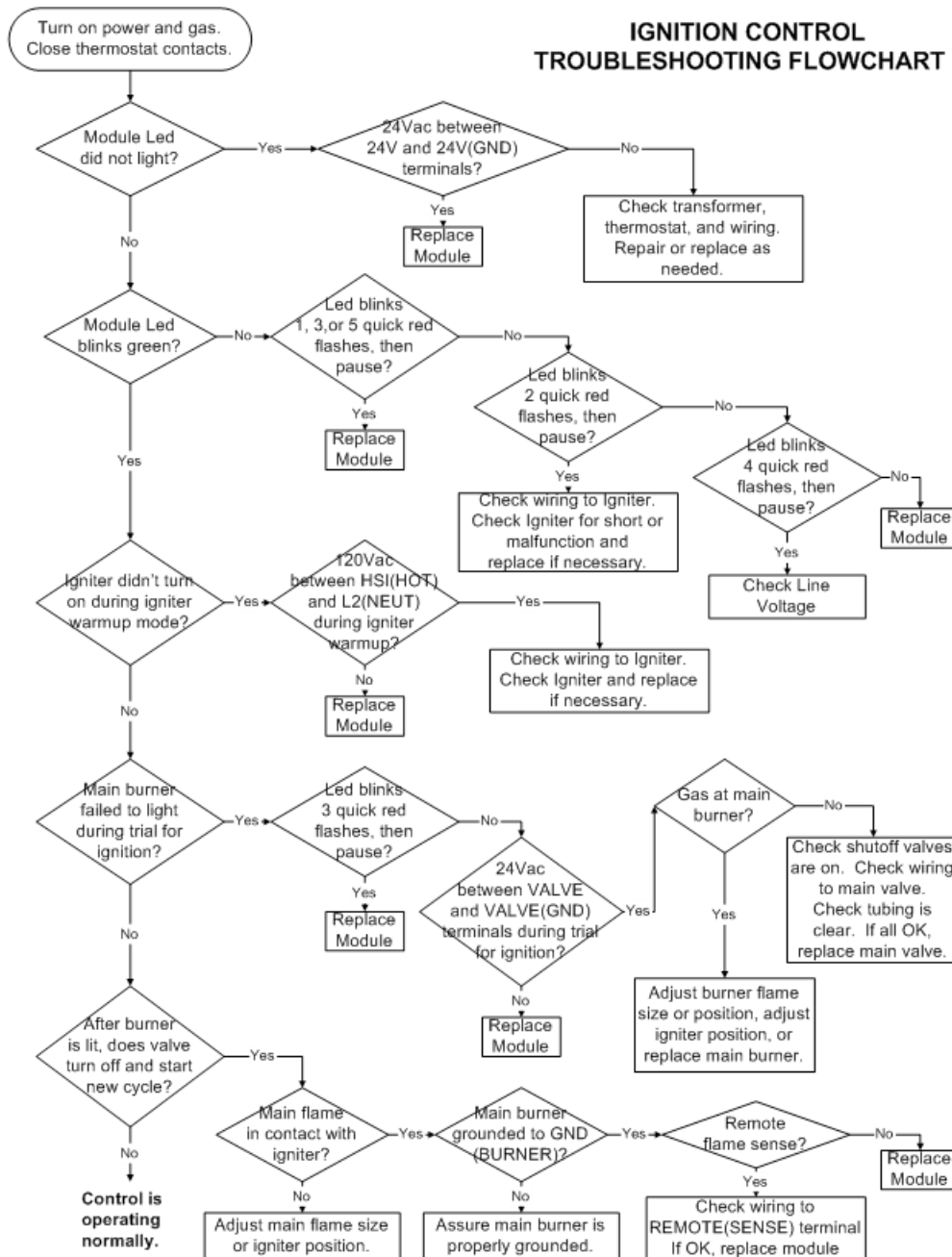

Turn OFF Manual Override toggle switch(s) on the left side of the motor box.

Note: Carbon builds up inside of the dome.

Check that the right gas is being used. Make sure Air Shutter Assembly is open to the manufacture recommendation. Clean the Inlet Ring and Air Screen. If using propane have to clear the carbon buildup run oven at 850F for three hours.

Temperature exceeding 30F above the set point: Adjust low flame setting for the temperature to drop down 1 degree for every 30 seconds.

GAS BURNER PARTS ISOMETRIC VIEW ▶

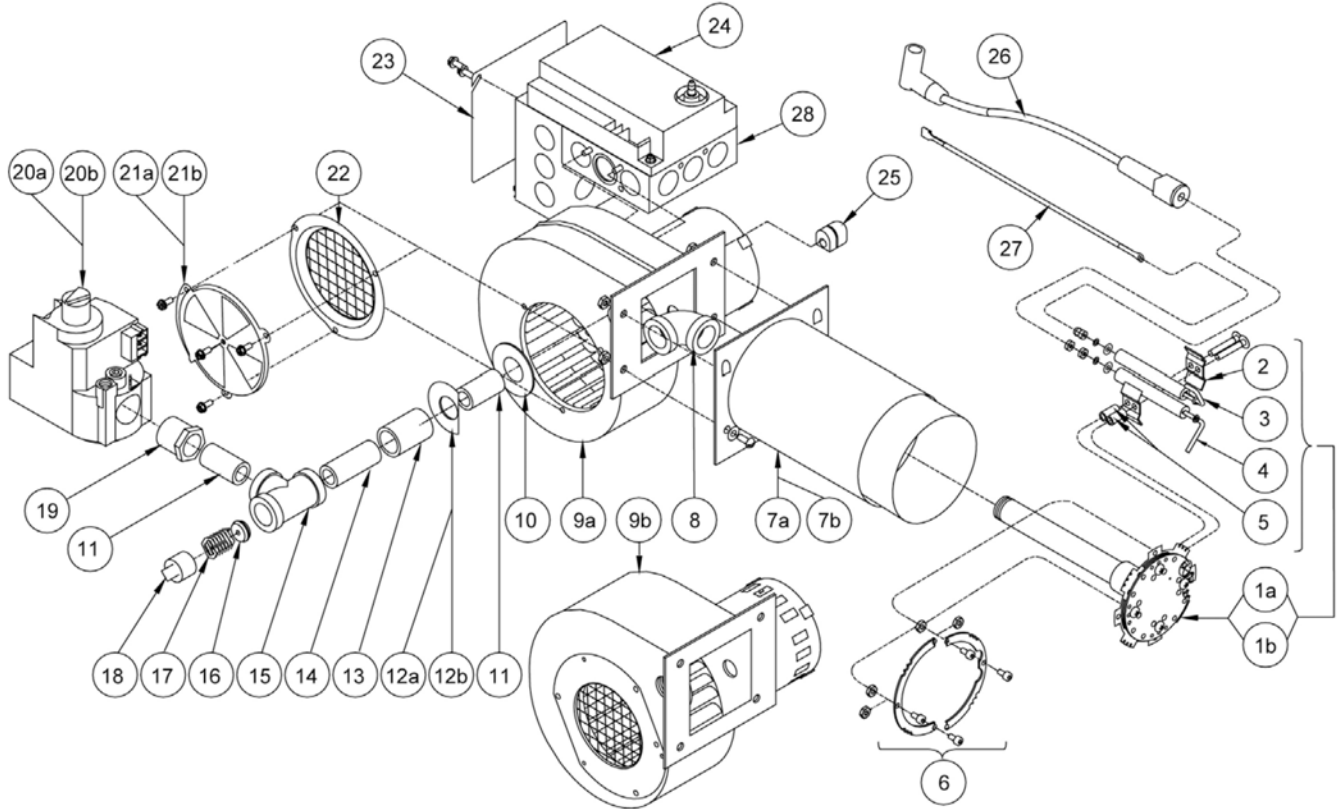

Item #	Part #	Description	Qty
1a	5236-20	EC200 Burner Head Assembly	1
1b	5236-19	EC300 Burner Head Assembly	1
2	5232-25	Flame and Spark Rod Bracket	2
3	5236-16	EC200/EC300 Spark Rod Assembly	1
4	5236-18	EC200/EC300 Flame Rod Assembly	1
5	8452-44	Bracket Spacer	2
6	5236-43	Air Restrictor Pack Includes Orifice (.173), Orifice Spring and Hardware	1
7a	5236-13	EC200 Blast Tube	1
7b	5236-14	EC300 Blast Tube	1
8	8495-04	1/2" Elbow	1
9a	8437-57	EC200 Motor Blower Assembly (Includes Wheel and Motor)	1
	5236-64	EC200 Blower Wheel	1
	5236-66	EC200 Blower Motor	1
9b	8437-56	EC300 Motor Blower Assembly (Includes Wheel and Motor)	1
	5236-65	EC300 Blower Wheel	1
	5236-67	EC300 Blower Motor	1

Parts List for EC200

Item #	Part #	Descriptions	Qty
10	5236-26	EC200/EC300 Washer EC200	4
		EC300	7
11	8487-50	1/2" Close Nipple	2
12a	5236-17	EC200 Special Washer	1
12b	5236-15	EC300 Special Washer	1
13	8493-67	1/2" Full Coupling	1
14	8487-52	1/2" X 2" Long Nipple	1
15	8494-02	1/2" Tee	1
16	5726-72	R Main Spud-173 Dr (#17) Orifice	1
17	6622-30	Orifice Spring	1
18	8496-17	1/2" Square Solid Plug Male	1
19	8492-51	3/4" X 1/2" Hex Bushing	1
20a	8419-70	EC200 -Redundant Combination Slow Opening Valve	1
20b	8419-75	EC300 Direct Spark Gas Valve Slow Opening Valve	1
21a	5236-48	Air Shutter Assembly EC200	1
21b	5236-47	Air Shutter Assembly EC300	1
22	5236-35	Inlet Ring And Air Screen Weldment EC200 Only	1
23	8480-37	4" X 4" Box Cover	1
24	8429-51	EC200/300 Control	1
25	8484-75	Strain Relief	1
26	8505-93	SAEJ2031 Ignition Cable Assembly	1
27	8505-94	Flame Rod Wire Assembly	1
28	5236-23	Control Assembly (Includes Control; Transformer and Box)	1

Not Shown

8452-16	Mounting Flange Kit
8447-30	120/208/240-24V 40V Transformer
7400-20	Wire Kit

Important: Availability of parts as well as specifications are subject to change without notice. Please consult factory for item availability. Avoid errors in parts selection, when ordering, use complete Midco Part number and description. Furnish burner model number, bill of material number and date code from the Specification Plate located on the burner.

OVEN FAN GSV 009-016 ▶

Description

Exhaust fan for installation at the chimney termination point, vertically or side-wall venting. Assures a negative pressure in the entire chimney system.

The fan housing is hinged and the top can be opened for easy service/access to stack.

Material

The housing is made of cast aluminum with a thickness of 3/16" and is corrosion resistant. Axial vanes in stainless steel, dynamically and statically balanced to assure low noise levels and vibration-free operation.

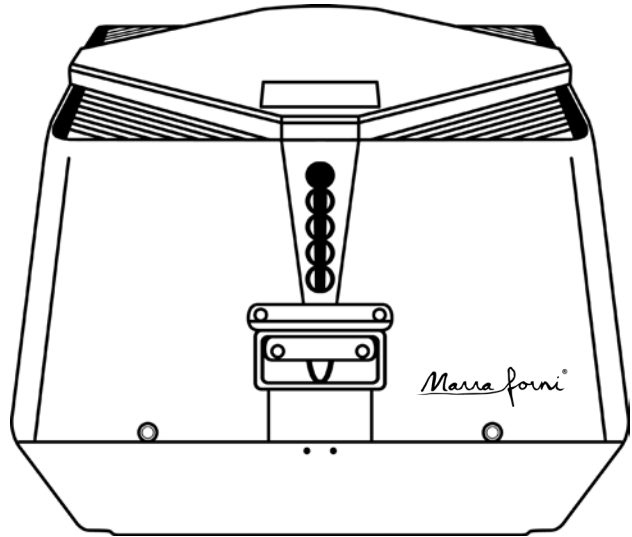

Motor

It features a split capacitor motor which is totally enclosed. Class H insulated, IP54 Protection Class. Sealed ball bearings. Variable Speed. Thermal overload protection.

Standard Equipment

2"x4" or 4"x4" junction box with cover and conduit Bird Screen

Optional Equipment

5amp or 8amp fan speed control.

Gasket.

Fan proving switch.

Listings

ETL listed to:

UL705 - Standard for Power Ventilators

UL762 - Standard for Power Roof Ventilators for Restaurant Exhaust Appliances

ULC-S645-93 - Standard for Power Roof Ventilators and Commercial/Institutional Kitchen Exhaust Systems

Approvals

CE Compliant

Warranty

2 year factory warranty on the entire fan

10 year warranty against corrosion perforation

Manufactured at an ISO9001 certified plant

OVEN FAN GSV 009-016 Specifications ▶

Model		GSV 009	GSV 012	GSV 014	GSV 016	
Discharge		Vertical				
Fan Type		Axial Vane				
Max. Discharge Velocity	FPM	2,351	2,592	2,593	2,169	
Actual Discharge Velocity	FPM	5.9 x CFM	2.9 x CFM	1.9 x CFM	1.2 x CFM	
Voltage		1 x 120 V AC				
RPM		1600				
Amps	A	0.5	1.4	2.9	5.8	
Power Ratings	kW	0.025	0.10	0.16	0.35	
Weight	lbs	28	46	60	86	
	kg	12	18	26	35	
Dimensions	A	in	9.85	11.03	13.20	14.97
		mm	250	280	335	380
	B x B	in	12.21	15.37	19.11	22.85
		mm	310	390	485	580
	C x C	in	9.46	12.22	15.17	18.32
		mm	240	310	385	465
	D Ø	in	8.63	10.72	13.04	14.26
		mm	219	272	331	362
	E	in	2.76	3.15	3.94	4.53
		mm	70	80	100	115
Temperature Rating	Interm.	575°F/300°C				
	Cont.	482°F/250°C				
Motor Starter Required		No	No	No	No	
Variable Speed Motor		Yes	Yes	Yes	Yes	

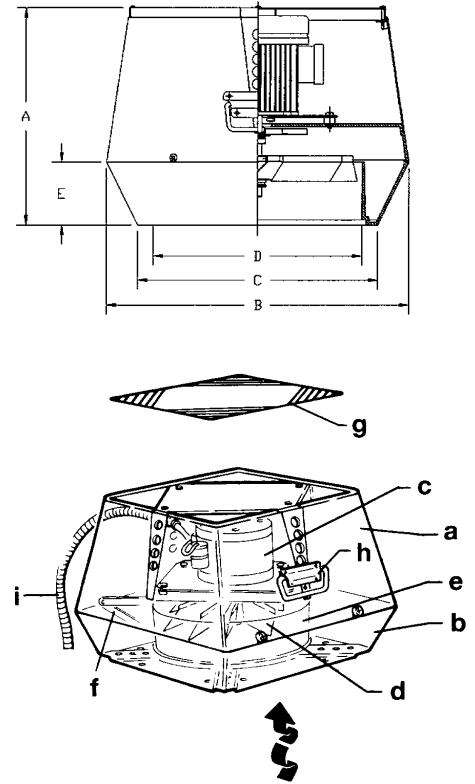

Sound Diagram

Model	Lw dB (measured in accordance with ISO 3744)								Lp dB(A)
	125Hz	250Hz	500Hz	1000Hz	2000Hz	4000Hz	8000Hz		
GSV 009	57	55	54	49	40	35	26	26	
GSV 012	64	62	61	55	51	46	40	33	
GSV 014	71	70	68	61	56	50	44	40	
GSV 016	76	76	70	65	60	55	49	44	

- a Top Section
- b Bottom Section
- c Motor
- d Axial Vane
- e Inlet for Axial Vane
- f Locking Hinge
- g Bird Screen
- h Carrying Handle
- i Wiring Conduit

Capacity

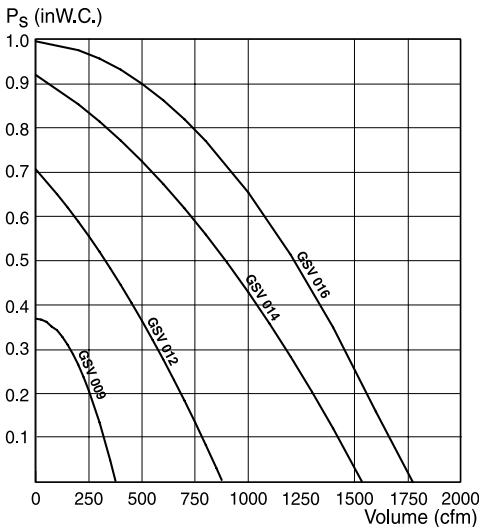

Plume Height

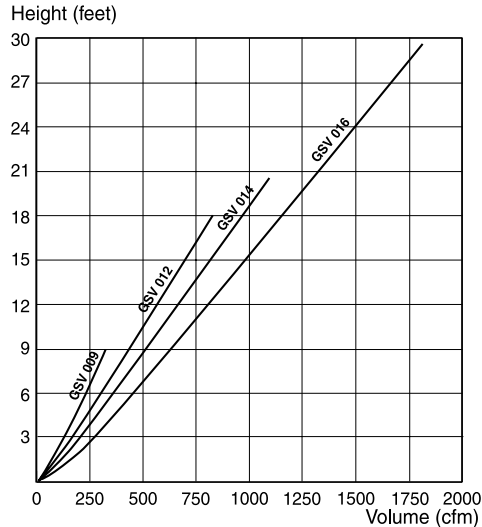



Top Ten Reasons You're Going to Love Your New Oven

1. Our Italian-style prep tables are drafted by designers who understand the needs of Neapolitan pizza makers and have taken care to organize the space to meet those specifications.
2. All of our ovens are produced and fully assembled in the United States. They are not shipped in loose pieces and then assembled in the United States.
3. Our decks do not crack. Many brick oven owners know that at some point their deck will crack and require costly repairs or replacement (customers will not be pleased to bite down on a pebble of cement during their meal). Marra Forni uses refractory bricks that allow for expansion and contraction during the frequent temperature shifts which happen thousands of times over the life of the oven.
4. Our ovens are some of the lightest weight brick ovens in the industry, yet do not sacrifice quality. Many people never take weight load into consideration, but a lighter oven allows for greater flexibility when looking into leasing a new space.
5. Our products are preferred by professionals as well as teachers of the industry, including but not limited to Verace Pizza Neapolitana, all of the American Pizza Team, Whole Foods, and the Tony Gemignani School of Pizza.
6. Marra Forni forked dough mixers "fold" the dough rather than mixing it. This prevents the dough from becoming heated from the friction of being mixed, guaranteeing you a "cleaner" dough and a fresher-tasting end result. Let your oven cook your dough, not the mixer!
7. Our company is based in the United States and we stock all of our units, which means a faster ship time for our customers.
8. We offer our clients the option to fully customize the outside of their oven with an endless variety of tile colors and textures. We can even apply patterns, or the name of your restaurant on the front of your oven. With Marra Forni, your oven is more than just an appliance, it is a work of art.
9. We offer a wide variety of oven sizes and styles. Every kitchen deserves to reap the benefits of wood fired oven ownership, which is why we strive to design ovens that accommodate any volume of pizzamaking.

LIMITED WARRANTY

ALL WARRANTY SERVICE MUST BE PRE-APPROVED BY MARRA FORNI

Marra Forni[®]
Brick Oven Cooking Solutions

10310 Southard Drive
Beltsville, MD 20705
888.239.0575

Serial Number: _____

Name of Purchaser: _____

Date of Purchase: / /

Marra Forni warrants its equipment to the original purchaser against defects in material or manufacture for a period of (three years for Dome and Deck) and one year for all other parts from the original date of purchase, subject to the following exclusions and limitations.

EXCLUSIONS

The warranties provided by Marra Forni do not apply in the following instances:

1. Granite on the front of the landing zone is not covered by any WARRANTY (client has 3 days to inspect this item upon receiving of the equipment and report any damage.)
2. In the event that the equipment is improperly installed. Proper installation is the responsibility of the installer; proper installation procedures are prescribed by the Marra Forni Installation and Operation Manual.
3. In the event the equipment is improperly or inadequately maintained. Proper maintenance is the responsibility of the user; proper maintenance procedures are prescribed in the Marra Forni Installation and Operation Manual. Burner problems resulting from debris or ash in the burner well will not be covered by the warranty. Call with questions regarding maintenance frequency.
4. In the event that the failure or malfunction of the appliance or any part thereof is caused by abnormal or improper use or is otherwise not attributable to defect in material or manufacture.
5. In the event that the appliance, by whatever cause, has been altered from the condition in which it left the factory.
6. In the event that the Marra Forni rating plate has been removed, altered or obliterated.
7. Parts that would be normally worn or replaced under normal conditions.
8. Normal cracking due to expansion and contraction stress relief in the deck and dome.
9. Damage resulting from the use of chemical cleaning products in the oven, as well as any damage from liquids or chemicals, including water, being poured or sprayed into the oven.
10. Damage from high voltage such as improper line voltage or lighting.

If any oral statements have been made regarding this appliance, such statements do not constitute warranties and are not part of the contract of sale. This Limited Warranty constitutes the complete, final and exclusive statement with regard to warranties.

THIS LIMITED WARRANTY IS EXCLUSIVE AND IN LIEU OF ALL OTHER WARRANTIES WHETHER WRITTEN, ORAL OR IMPLIED, INCLUDING, BUT NOT LIMITED TO, ANY WARRANTY OF MERCHANTABILITY OR FITNESS FOR PARTICULAR PURPOSE OR WARRANTY AGAINST LATENT DEFECTS.

LIMITATIONS OF LIABILITY

In the event of warranty claim or otherwise, the sole obligation of Marra Forni shall be the repair and/or replacement, at the option of Marra Forni, of the appliance or component or part thereof. Such repair or replacement shall be at the expense of Marra Forni with the exception of travel over 100 miles or two hours, overtime, and holiday charges which shall be at the expense of the purchaser. Any repair or replacement under this warranty does not constitute an extension of the original warranty for any period of the appliance or for any component or part thereof. Parts to be replaced under this warranty will be repaired or replaced at the option of Marra Forni with new or functionally operative parts. The liability of Marra Forni on any claim of any kind, including claims based on warranty, expressed or implied, contract, negligence, strict liability or any other theories shall be solely and exclusively the repair or replacement of the product as stated herein, and such liability shall not include, and purchaser specifically renounces any rights to recover, special, incidental, consequential or other damages of any kind whatsoever, including, but not limited to, injuries to persons or damage to property, loss of profits or anticipated profits, or loss of use of the product.

TO SECURE WARRANTY SERVICE

If you claim a defect covered by this Limited Warranty, contact: Marra Forni, Attn: Service Department, 10310 Southard Dr. Beltsville MD 20705 USA Phone 888.239.0575 / Fax. 240.667.7991

Limited Warranty Registration

2 Year Deck and Dome Warranty
1 Year Parts and Labor Warranty

Complete this form and return it to Marra Forni within 30 days of receipt of purchase.

This is to Certify that Marra Forni products have been received by:

Located at:

Date of Receipt:

Product Serial Number(s):

Description of Equipment

Thank you for choosing that Marra Forni line to fulfill your restaurant equipment needs. Please return this warranty registration form within 30 days of receipt of purchase. If you have any questions, please contact us during regular business hours (9 am to 5 pm, Monday through Friday) at 888.239.0575.

DO NOT THROW THIS MANUAL AWAY.
REVIEW WARRANTY BEFORE INSTALLING OVEN.



Marra forni[®]
Brick Oven Cooking Solutions

10310 Southard Drive | Beltsville, MD 20705 | www.marraforni.com | 888.239.0575

Rev 2/2021