

Designed and manufactured with efficiency, durability, and modularity in mind, Marra Forni Electric Series stackable ovens achieve high-volume cooking and baking production by vertically integrating modular oven decks to reduce the overall kitchen footprint. The ovens are available in several sizes, and can be vertically stacked up to four decks in height. With temperatures ranging from 200-950°F (93-510°C), the versatile ovens are ideal for high-volume pizza making, as well as artisanal baking and traditional cooking. The ovens can be configured as multiple-deck systems using a common chassis, or placed singly as needed based upon production demand.

The ELST series is designed as a simultaneous multi-purpose cooking system, or for high outputs when baking similar products. Each oven is operated by a fully-programmable digital touchscreen controller, with individually-adjustable upper and lower temperatures to maximize thermal control for ideal baking results. The ovens feature a large illuminated cooking area, as well as a wide windowed door that is balanced by both counterweights and dual heavy-duty coil springs for durability and high-volume use. Each oven chamber operates using high-efficiency radiant infrared heating technology located within the stone-hearth deck. The deck features refractory brick plates of a Marra Forni-specific composition including volcanic material. A controlled vent on each deck allows for individual humidity evacuation as needed for each particular cooking application.



Standard Features

- MarraStone® stone hearth deck is of a refractory brick that includes volcanic material. This deck is both durable and highly porous, and is capable of maintaining cooking temperatures up to 950°F (510°C) for consistent high-volume production
- MarraSmart® digital touch screen control technology is fully programmable and provides complete control of oven cooking conditions, as well as automatic timed on/off with menu selection and QR code scanning for maintenance videos. Individual controls permit each oven to be controlled independently, with individual programs if desired
- Highly efficient upper and lower radiant infrared heaters ensure deck and chamber temperature consistency
- Full width front hinged door features a large, recessed tempered glass window for high visibility of internal cooking chamber. Large, insulated full-length safety door handle is cooler to the touch to help prevent injury when opening and closing the door
- 200-950°F (93-510°C) cooking temperature range
- Cooking cavity is designed to accept two side-by-side 18 x 26" (457 x 660mm) full-size sheet and baking pans
- 7" (178mm) interior cook deck height
- Standard interior lighting
- Stainless steel exterior front and doors
- Galvanneal steel exterior sides, rear and interior
- Standard manually controlled damper vent for each oven deck
- Mobile steel stand with 5-1/2" (140mm) locking casters
- Manufactured in the U.S.A.

Cooking Capacity (per deck, typical)

- 8" (200mm) pizzas: 15
- 10" (250mm) pizzas: 11
- 12" (300mm) pizzas: 7
- 16" (400mm) pizzas: 4
- 18" (460mm) pizzas: 2

Production capacity varies depending upon type of food product being cooked, food preparation and set temperature.

Total Cooking Surface 8.22 sq. ft. (0.76 sq. m)

Cooking Deck Dimensions 37 x 32" (940 x 813mm) per deck



This appliance has been certified by ETL Intertek as having been tested in accordance with EPA method 202 for compliance with UL 710B, *Standard for Recirculating Systems*. The use of an additional Type 1 hood is not required for cooking effluent removal, provided this appliance is installed with a direct venting system in accordance with the manufacturer's instructions and all applicable local code requirements.

UL 197 | CSA C22.2 No. 109 | NSF/ANSI 4

Configuration Options (Check all that apply)

Options

- Direct Ventilation (quoted separately)
Note: requires Exhaust Fan and Vent Cap options
- Exhaust Fan with Variable Speed Fan Control
- Top-Mounted Stainless Steel Ventilation Cap
- Additional Modular Cooking Deck(s)
Note: requires additional dedicated electrical connection(s) and additional ventilation. Refer to appropriate spec sheet for details
- One-stack (ELST37-32/1)
- Two-stack (ELST37-32/2)
- Three-stack (ELST37-32/3)
- Four-stack (ELST37-32/4)

Accessories

- Dough Tray
- Dough Tray Lid(s)
- Dough Tray Dolly
- Standard Peel Tool Kit
- Deluxe Peel Tool Kit
- Wall Mounted Tool Rack

ELECTRIC STACKABLE Series

ELST37-32/2

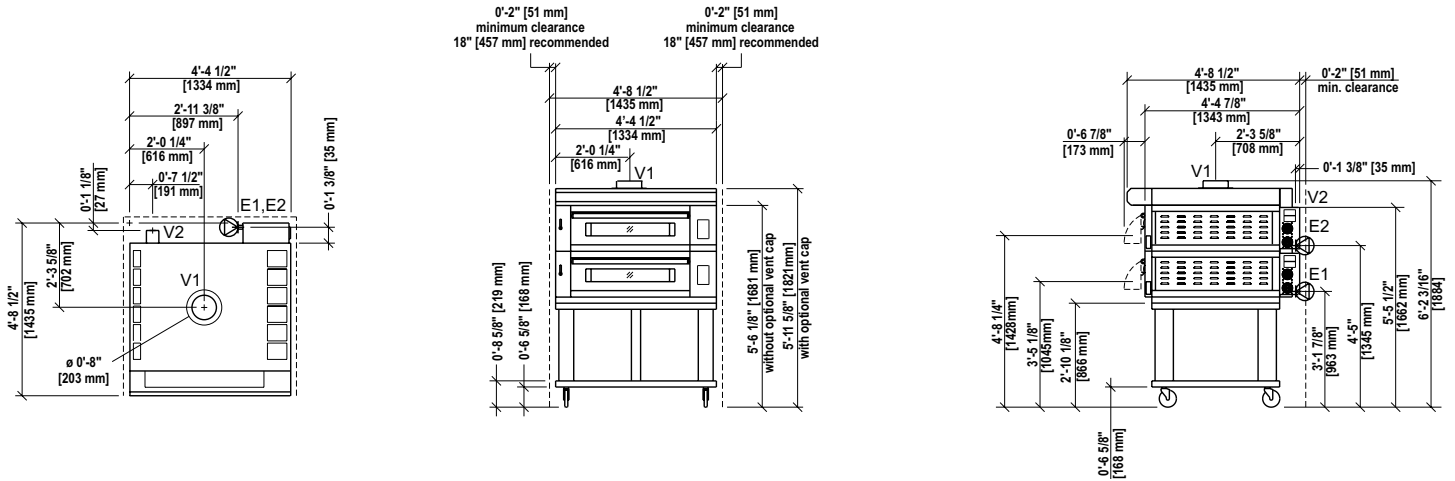

Electrical connection(s)
Strain relief provided for access to internal terminal block. Direct flexible connection to be provided by others. If multiple oven decks are used, each deck requires a unique electrical supply connection.

- V1 Ventilation connection, with vent cap** (center round vent)
Required for direct vent connection. Direct venting also requires exhaust fan option with variable speed fan control.
- V2 Ventilation connection, without vent cap** (rear square vent)
Passive vent. For use under a Type 1 exhaust hood only.

Electrical Connection Requirements

Electrical supply	Electrical power rating	Peak load ampacity	Min. supply ampacity	Max. breaker/disconnect
208-240V 50/60 Hz/3Ph	18.1 kW	60A	80A	80A

If multiple oven decks are installed, each deck requires a unique electrical connection complying with the specifications listed.

Dimensional Information

- Minimum clearance: 2" (51mm) on all sides and rear from combustible surfaces, 0" (0mm) from non-combustible surfaces. 18" (450mm) side clearance recommended for service access
- Exterior: (H x W x D): 66-1/8" x 52-1/2" x 56-1/2" (1768 x 1334 x 1435mm)
- Shipping: (H x W x D): 88" x 80" x 68" (2235 x 2032 x 1727mm)
- Weight: 1,115 lbs. (506 kg)
- Crated Weight: 1,555 lbs. (705 kg)
- Freight Class: 77.5, shipped LTL

Specification

ELST37-32/2 Item # _____

Unit will be an ETL-listed Marra Forni ELST37-32/2 modular oven, intended for cooking and baking pizza and other approved food products.

Operating voltage will be 208-240V, 50/60Hz, 3Ph.

Unit will feature a stone hearth cooking deck composed of a unique refractory brick composition, including volcanic material, to provide and maintain cooking temperatures up to 950°F (510°C).

Unit will feature a programmable electronic controller with individually-adjustable upper and lower temperatures, selectable menus, and timed on/off features to accommodate a variety of cooking requirements.

Unit will be of modular design, permitting oven decks to be used individually, or stacked up to four units high, each with unique cooking parameters.

Ventilation Connection Requirements

Connection (direct vent)	Volume (per deck)	Static Pressure
8" (203mm) round collar	130 CFM 221 m ³ /h	0.01" W.C. 2.5 Pa

Oven may be installed with an approved direct vent system, or under a Type 1 exhaust hood system. Ventilation system must comply with all applicable local and national codes.

If direct ventilation is desired, a Marra Forni-designed optional powered vent system is available, and is strongly recommended. This option also requires both the exhaust fan (with variable speed fan control) and ventilation cap options.

If not using a Marra Forni-supplied direct ventilation connection, determining correct ventilation and code compliance is the responsibility of others.

If multiple oven decks are installed, each deck has individual exhaust air volume requirements complying with the specifications listed.

Unit cooking area will measure 37" W x 32" D x 7" H (940 x 813 x 178mm) per deck.

Heating to be accomplished by upper and lower radiant infrared electric heating elements.

Unit will include a wide hinged front door, featuring an insulated handle, tempered glass window, counterweights and heavy-duty coil springs.

Unit will include interior lighting for full-time monitoring of the cooking process.

Unit exterior will feature stainless steel front and doors, with galvanized steel sides and rear. Unit will feature galvanized steel interior.

Unit will include a mobile steel stand with four (4) locking casters.

Unit will be manufactured in the U.S.A. and comply with all applicable FTC requirements for this status.

All specifications are subject to change without notice, based on Marra Forni's commitment to ongoing product development and improvement measures. Ovens are designed only for the cooking of manufacturer-approved food products in commercial and institutional settings, and should not be used for any other purpose.